

City of  
**Melbourne**  
The Harbor City



---

Technical Specifications and Standards for Construction of Sanitary Lift Stations

Appendix A: Technical Specification Detail Drawings for Lift Stations

Appendix B: Approved Products List

---

Approved:

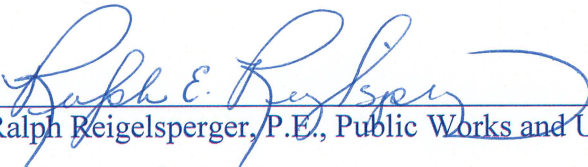
  
Ralph Reigelsperger, P.E., Public Works and Utilities Director

Date: 11.13.2020

Approved:

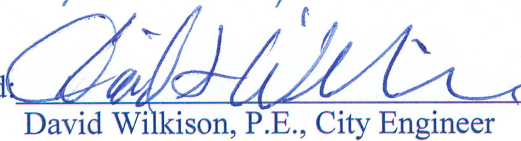
  
David Wilkison, P.E., City Engineer

Date: 11/16/2020

Latest Revision Date: 08/12/2020

Effective Date: 08/12/2020

City of  
**Melbourne**  
On Florida's SpaceCoast



# Technical Specifications and Standards for Construction of Sanitary Lift Stations





# Technical Specifications and Standards for Construction of Sanitary Lift Station Systems

---

## TABLE OF CONTENTS

<b>Section L1000</b>	<b>General Information</b> .....	4
L1001	Licenses.....	4
L1002	Contractor Scope of Work.....	4
<b>Section L1100</b>	<b>Site Requirements and Design</b> .....	5
L1101	Site Sizing and Easement Requirements.....	5
L1102	Site Accessibility.....	5
L1103	Site Fencing.....	5
L1104	Area Flooding.....	7
L1105	Design Flow.....	7
<b>Section L1200</b>	<b>Wet Well and Valve Design</b> .....	8
L1201	Wet Well Structure Inspection.....	9
L1202	Wet Well Placement.....	9
L1203	Wet Well Encapsulation and Sealing.....	10
<b>Section L1300</b>	<b>Pump and Motor Requirements</b>	11
L1301	Pump and Motor Sizing	11
L1302	Pump Equipment Design and Construction	11
L1303	Placement of Pump Equipment	15
L1304	Pump Equipment Warranty, Parts and Service	15
L1305	Pump Station Pipe, Valves, and Fittings	16
L1306	Pump Station Water System	17
L1307	Pump Station Standby Power Generator	17
<b>Section L1500</b>	<b>Pump Station Electrical Power and Control Systems</b>	20
L1501	Electrical Connections.....	20
L1502	Electrical Service.....	20
L1503	Construction Materials.....	21
L1504	Pipe.....	21
L1505	Control-Electrical Service Mounting.....	21
L1506	Control Panel Components.....	21
L1507	Lift Station Operations.....	22
L1508	TCU Operation.....	22
L1509	UL Label.....	22
L1510	Manufacturer Nameplate.....	23
L1511	Wiring.....	23
L1512	Quality Control and Testing.....	23
L1513	Remote Terminal Unit (RTU).....	23
L1514	Electrical Grounding System.....	24
<b>Section L1600</b>	<b>Required Submittals for Pump Stations</b> .....	24
<b>Section L1700</b>	<b>Inspection and Start-Up Testing</b> .....	25
<b>Section L1800</b>	<b>Wastewater Pump Stations Not Accepted by City</b> .....	25



# Technical Specifications and Standards for Construction of Sanitary Lift Station Systems

---

<b><u>Section L1900</u></b>	<b><u>Installation Guide</u></b> .....	28
<b><u>Section L2000</u></b>	<b><u>Final Clean-Up</u></b> .....	28
<b><u>Section L2100</u></b>	<b><u>As-Built Survey and Record Drawings</u></b> .....	28
<b><u>Section L2200</u></b>	<b><u>Requirements for Scheduling Pre-Final Inspection</u></b> .....	29
<b><u>Section L2300</u></b>	<b><u>Maintenance Bond</u></b> .....	30
<b><u>Appendix A- Technical Details</u></b>		
<b><u>Appendix B- Approved Products List</u></b>		



# Technical Specifications and Standards for Construction of Sanitary Lift Station Systems

---

## **L1000      GENERAL INFORMATION**

These specifications cover the design, drawings, specifications, installation, inspection, testing and acceptance of 'City-Accepted' wastewater pumps stations.

The construction of sanitary lift stations shall be in accordance with the most current edition of Chapter 62-604 Collection Systems and Transmission Facilities Florida Administrative Code, Florida Building Code, City of Melbourne Code of Ordinances, and these technical specifications. In case of conflict, Chapter 62-604, Florida Administrative Code (F.A.C.) shall prevail.

If improvements are being made under the jurisdiction of another governmental entity and the requirements differ, the more stringent shall apply.

All referenced Industry Specifications and Standards are to be latest revision.

All such wastewater pump stations shall be submersible type stations. The type and basis for design of all other stations shall be reviewed with the City and the approval obtained before proceeding with design.

Only equipment compatible with existing components and operations will be considered. The intent of this provision is to insure uniform operation and to minimize spare part inventory. Interchangeability with existing equipment and emergency connection to this equipment with no adverse effect on operations will be required.

All wastewater pump stations that are not accepted by the City, yet intend to discharge into the City's wastewater collection system shall have a current repair and maintenance contact name and telephone number visibly attached to the outside face of the control panel. The owner shall keep access available to the pump station at all times. The City shall have the right to enter said station in times of emergencies to allow control of wastewater discharged into the City's system.

Contractor/Owner will be responsible for all permits and fees required by all organizations responsible for such fees and permits including, but not limited to, City, County, State, and Federal Governments.

## **L1001      LICENSES**

All Contractors must have the following current and valid license.

- State of Florida Certified Underground Utility and Excavation Contractor License.

## **L1002      CONTRACTOR SCOPE OF WORK**

The Contractor shall install all public and private lift stations and appurtenances in accordance with these Technical Provisions for Construction of Sanitary Lift Station Systems. Any deviation from these specifications must be approved in writing by the City prior to commencement of construction of facility affected.

The Contractor shall furnish all labor, materials, tools and equipment necessary or incidental to the construction. Contractor shall obtain and pay all permits, official inspections by the City of Melbourne and other official fees in connection with the work.

The Contractor shall attend a preconstruction conference and receive a letter to precede



# Technical Specifications and Standards for Construction of Sanitary Lift Station Systems

---

with approved construction drawings from the City Engineering Department a minimum of two working days prior to commencement of construction. The Contractor shall submit a "Start Work" letter a minimum of 48 hours in advance of the start of construction to the City's Engineering Department.

The Contractor shall not operate any valve nor remove any thrust block/restraining joint from City owned mains except under direct supervision of a representative from the City.

The Contractor shall not backfill any fitting, thrust block, restrainer gland, valve, and/or any sanitary structures until such appurtenances have been inspected in place by a designated representative of the City. All such inspections shall be scheduled a minimum of two (2) working days in advance.

Contractor shall communicate in writing to the property owner at the completion of the project that privately owned systems and appurtenances shall be properly maintained and operated in accordance with all applicable codes and regulations.

## **L1100 SITE REQUIREMENTS AND DESIGN**

### **L1101 SITE LAYOUT, SIZING, AND EASEMENT REQUIREMENTS**

Pump station sites shall be laid out and sized as delineated in Technical Detail A-501 Typical Lift Station Site Plan. Site must meet all setback and landscape requirements found in Code of Ordinances, Part III, Appendix B, Article VI, Section 2(O). Lift station site within limits of utility easement shall be uniform and level with top elevations of wet well and valve vault 3 inches above finish grade. Finish grade is defined as top of bedding rock within confines of pump station security fence.

The Developer shall dedicate pump station by warranty deed or plat to the City. Dedicated easement shall also be required around the site as delineated in Technical Detail A-501. In general, the site for the paved access road shall also be dedicated to the City by warranty deed or plan. An exception to this requirement may be allowed on a case-by-case basis in the form of an ingress/egress easement for the access road.

### **L1102 SITE ACCESSIBILITY**

The pump station shall be readily accessible by maintenance vehicles during all weather conditions. The access road to the pumping station shall be paved. The facility shall not be located in road right-of-way. In a phased development, a stabilized access road may be accepted during the initial phase with paving to be accomplished in the later phase.

### **L1103 SITE FENCING**

In general, all pump station sites shall be fenced. However, exception to this requirement may be made for pump station servicing residential areas only, on a case by case basis and subject to sufficient landscaping screening as approved by the City.

The Contractor shall furnish and erect a chain link fence and gate with material to be installed in accordance with the project specifications and in conformity with the lines, grades, notes, and typical sections shown in plans and Technical Detail A-501. Material specified as follows unless otherwise approved by the City.

#### **L1103-1 MATERIAL DETAILS**

The fabric, posts, fastenings, fittings, and other accessories for chain link fence shall meet



## Technical Specifications and Standards for Construction of Sanitary Lift Station Systems

---

the requirements of AASHTO M 181 with the following changes:

- The weight of coating on wire fabric shall be 1.2 ounces of zinc per square foot (class B).
- The galvanizing of steel materials shall be hot dipped galvanized.
- The weight of coating on posts and braces shall be 1.8 ounces of zinc per square foot, both inside and outside to meet the requirements of AASHTO-M-111.

The base metal of the fabric shall be a good commercial quality 9 gauge steel wire. The fabric shall be of uniform quality, and shall be six-foot (6') high with a two-inch (2") mesh size. All posts and rails shall be in accordance with the following schedule:

- End, corner and pull posts – 2 3/8" O.D., schedule 40
- Line posts and gate frames – 2" O.D., schedule 40
- Gate posts – 3" O.D., schedule 40
- Post braces and top rail – 1 5/8" O.D., schedule 20
- Tension wire shall be 0.177 inch coiled spring wire tensioned along the bottom of the fabric and shall be coated similarly to the wire fabric.
- Miscellaneous fittings and hardware shall be zinc coated commercial quality or better steel or zinc coated cast or malleable iron as appropriate for the article.
- Post caps, designed to provide a drive fit over the top of the tubular post to exclude moisture, shall be provided.
- Fencing fabric, posts, rails, wire and caps shall be vinyl coated, prior to installation, and shall be green in color.
- Fencing constructed of material other than that specified shall not be the responsibility of the City.

### **L1103-2 FENCE POSTS**

All posts shall be set three feet (3') deep in concrete footings, 12" diameter for line posts, gate and corner posts. After the posts have been set, aligned, and plumbed, the hole shall be filled with 2500 psi concrete. The concrete shall be thoroughly worked into the hole so as to leave no voids. The exposed surface of the concrete shall be crowned to shed water. End corner, pull and gate posts shall be braced to the nearest post with horizontal brace used as a compression member and a galvanized 3/8" steel truss rod and truss tightener used as a tension member.

Corner posts and corner bracing shall be constructed at all changes of fence alignment of 30 degrees or more. All chain link fences shall be constructed with a top rail and bottom tension wire.



# Technical Specifications and Standards for Construction of Sanitary Lift Station Systems

## **L1103-3 GATES**

Swing gates shall be two (2) six-foot (6') wide double hung gates and hinges to swing through 180 degrees from closed to open and shall be complete with latches, locking device, stops keeper, hinges, fabric and braces. Gates shall be the same height as the fence and the gate fabric shall be the same as the fence fabric.

Gate leaves less than eight feet (8') wide shall have truss rods or intermediate braces and gate leaves eight feet (8') or more in width shall have intermediate braces and diagonal truss rods or shall have tubular members as necessary to provide rigid construction, free from sag or twist.

## **L1103-4 PLACING FENCE FABRIC**

The fabric shall not be placed until the posts have been permanently positioned and concrete foundations have attained adequate strength.

The fabric shall be placed by securing one end and applying sufficient tension to remove all slack before making permanent attachments at intermediate points. The fabric shall be fastened to all corner, end, and pull posts by substantial and approved means. Tension for stretching the fabric shall be applied by mechanical fence stretchers.

## **L1104 AREA FLOODING**

Wastewater pumping station structures and electrical/mechanical equipment shall be protected from physical damage from a 100-year flood. Regulations of Local, State, and Federal agencies regarding flood plain construction shall be considered.

## **L1105 DESIGN FLOWS**

Design flows shall be based upon the total ultimate development flow from all contributory areas to the pump station. The design average daily flow shall be based on Equivalent Residential Unit (ERU) determination and computed as outlined in the City of Melbourne Comprehensive Plan and Concurrence Ordinances.

The design pumping capability of the station shall be based upon the Peak Design Flow which shall be calculated by multiplying the design average flow with the applicable minimum peaking factors as outlined below:

### **Minimum Peaking Factor**

<b><u>Design Average Daily Flow</u></b>	<b><u>for Peak Design Flow</u></b>
Flows to 100,000 GPD	4.0
100,000 GPD to 250,000 GPD	3.5
250,000 GPD to 1,000,000 GPD	3.0
Flows greater than 1,000,000 GPD	2.5

For design average daily flow above 2,000,000 GPD, peaking at factors less than 2.5 may be considered if substantiated by extensive data. Under no circumstances shall peaking factors less than 2.0 be allowed.





## Technical Specifications and Standards for Construction of Sanitary Lift Station Systems

---

### **L1200 WET WELL, VALVE VAULT DESIGN, AND RECEIVING MANHOLE DESIGN**

Wet well shall be minimum six-foot (6') diameter and shall have a minimum four and one-half-foot (4 ½') depth below the lowest invert. Additional depth shall be provided based on station design and cycle time.

Pumping levels shall be adjusted to provide a minimum capacity between normal operational water levels sufficient to allow a minimum of five (5) minutes between successive starts of the pumps.

Pump-off water levels shall provide adequate submergence to prevent pump inlet vortexing or air binding. Operational maximum water levels shall not exceed the invert elevation of the influent pipe.

The wet well floor shall have a minimum slope of 1H to 1V to the hopper bottom. The horizontal area of the hopper bottom shall be no greater than necessary for proper installation and function of the pump inlet.

No fixed interior ladders shall be permitted in the wet well.

Locate receiving manhole within limits of fenced-in area to allow isolation of wet well during bypass operations. Receiving manhole shall be coated with an approved high-build epoxy coating. Alternatively, an approved polymer concrete precast structure product for the receiving manhole may be provided. Refer to Appendix B: Approved Products List for allowable coatings and polymer concrete pre-cast structure products. Only one wastewater inlet connection shall be permitted to a wet well. All openings in wet well and valve vault shall be manufactured at foundry. No field coring is permitted without prior City approval.

Wet well shall be constructed of precast units. Cast-in-place shall not be permitted.

Precast wet wells shall conform to specifications for Precast Reinforced Concrete Sections, ASTM Designation C478, except as otherwise specified below:

The minimum wall thickness shall be eight inches (8") for all wet wells. Precast wet wells shall be constructed with a monolithic base structure as shown in Technical Detail A- 502. The minimum base thickness shall be 12 inches (12"). The precast top slab shall have thickness of 10 inches (10"). Concrete for wet wells shall be Type II, 4000 psi at 28 days. Barrel, top and base sections shall have tongue and groove joints. The date of manufacture and the name or trademark of the manufacturer shall be clearly marked on each precast section. Sections shall be cured by an approved method for at least 28 days prior to coating and shall not be shipped until at least two days after having been coated. Lifting rings or non-penetrating lift holes shall be provided for after having been coated. Lifting rings or non-penetrating lift holes shall be provided for handling precast wet well sections. Non-penetrating lift holes shall be filled with non-shrink grout after installation of the sections. Concrete surfaces shall have form oil, curing compounds, dust, dirt, and other interfering materials removed by sandblasting and shall be fully cured prior to the application of any coatings.

Interior of wet well shall be coated with an approved high-build epoxy coating. Alternatively, an approved polymer concrete pre-cast structure product for the wet well may be provided. Refer to Appendix B: Approved Products List for allowable coatings and polymer concrete pre-cast structure products.



## Technical Specifications and Standards for Construction of Sanitary Lift Station Systems

---

Terminal/receiving manholes, manholes with sewer force mains discharging into them, and other manholes that, in the opinion of the City, are to be adversely affected by corrosive gases shall be coated with an approved high-build epoxy coating. Existing manholes that are converted to receiving manholes for newly constructed force mains shall have the inverts and bench reconstructed to accommodate the force main discharge.

### **L1201 WET WELL STRUCTURE INSPECTION**

The quality of all materials, the process of manufacture, and the finished sections shall be subject to inspection and approval by the City. Such inspection may be made at the place of manufacture, or at the site after delivery, or at both places, and the section shall be subject to rejection at any time on account of failure to meet any of the specification requirements even though sample sections may have been accepted as satisfactory at the place of manufacture. Sections rejected after delivery to the job shall be marked for identification and shall be removed from the job at once. All sections which have been damaged after delivery will be rejected and, if already installed, removed and replaced, entirely at the Contractor's expense.

At the time of inspection, the sections will be carefully examined for compliance with the specified ASTM designation and with the approved manufacturer's drawings. All sections shall be inspected for general appearance, dimension, "scratch-strength" blisters, cracks, roughness, soundness, etc. The surface shall be dense and close-textured to form an integral watertight unit.

### **L1202 WET WELL PLACEMENT**

Base sections shall be placed on bedding rock conforming to the requirements on Technical Detail A- 502. The bedding rock shall be firmly tamped and made smooth and level to assure uniform contact and support of the precast structure.

A pre-cast base section shall be carefully placed on the prepared bedding so as to be fully and uniformly supported in true alignment and making sure that all entering pipes can be inserted on proper grade.

Pre-cast wet well sections shall be handled by lift rings or non-penetrating lift holes. Such holes shall be filled with non-shrink grout after installation of the wet well. The first precast sections shall be placed and carefully adjusted to true grade and alignment. All inlet pipes shall be properly installed so as to form an integral watertight unit. The sections shall be uniformly supported by the base structure and shall not bear directly on any of the pipes. Precast sections shall be placed and aligned to provide vertical alignment with a ¼ inch maximum tolerance per five (5) feet of depth. The completed wet well shall be rigid, true to dimensions, and water tight.

Valve vault floor shall slope to center and have a solid PVC floor drain with stainless steel grating. Floor drain shall be connected to wet well as shown in Technical Detail A-504. Drain line shall include one in-line "P" trap located under drain below valve vault, and a swing check valve shall be placed at the discharge of drain in wet well to prevent corrosive gases from entering valve vault.

All pipe openings shall be sealed with non-shrink grout.

Both the wet well and the valve vault shall be furnished with an access frame and cover. Equipment furnished shall include the necessary aluminum access frames



## Technical Specifications and Standards for Construction of Sanitary Lift Station Systems

---

complete with hinged and slide bar equipped, stainless steel upper guide holder, and level sensor cable holder. The frames shall be cased in structure at foundry with upper guide holder securely mounted above the pumps. Doors shall be of aluminum checkered plate. The access cover and frame with type 316 stainless steel hardware shall be installed as shown in Technical Detail A-502. Wet well cover shall be minimum of 30" x 48", valve box cover shall be minimum of 48" x 48" double door. Both covers shall be aluminum locking type similar. Larger size covers may be required to accommodate pump equipment. Grounding conductor cable shall be run within and through top slabs during their fabrication and connected to access frames as outlined in Section L1514 and Technical Detail A-505 Wet Well and Valve Vault Access Frame Grounding.

Buoyancy of wet well and valve vault structures shall be considered and adequate provisions shall be made for protection as part of lift station design. Wet well and valve vault structures shall be installed as shown on Technical Details A-502, A-503, and A-504. Wet well construction shall be in conformance with the pre-cast structure specifications and as outlined on the technical details.

Exterior of wet well to receive at foundry two coats (black over red) of coal tar epoxy paint (8mm dry film thickness each). This is to be continuous coating free of "pin holes" and/or voids and is to be applied in accordance with manufacturer instructions as not to void manufacturer's warranty. Technical specifications and general information concerning the specific coating used shall be supplied by the coating manufacturer and be included as part of the required submittals as outlined in Section L1600. After wet well top slab, base and all sections have been permanently set in place, seal outside at joints with non-shrink grout.

### **L1203 WET WELL ENCAPSULATION AND SEALING**

#### **L1203-1 SEALING SYSTEM**

All new wet wells shall be completely sealed at all the joints and risers by the applying a heat-shrinkable wraparound sleeve. All wet wells that are to be rehabilitated, or have the rings and covers raised or replaced, shall be completely sealed around the top crown section of the manhole with this same wraparound sleeve.

The heat-shrinkable wraparound sleeve shall consist of a two-piece sleeve (backing and adhesive) with a closure system and a G-type primer. It shall consist of irradiated cross-linked polyolefin sheeting, pre-coated with a layer of anti-corrosion adhesive and shall be designed to provide excellent resistance against mechanical damage during construction and in service. The backing shall have a minimum recovery of 39% for irregular or cone shapes. For symmetrical cylindrical shapes, a minimum backing recovery of 22% is required. The sleeve shall have a mastic-type adhesive, specially formulated to become fluid at temperatures achieved during installation and maintain flexibility in cold climates. Upon cooling, the adhesive shall form a tough, elastomeric protective layer, which will effectively prevent the ingress of ground water into the joints.

The sleeve shall be a heat-activated material applied with torch and shall be made from materials that provide high electrical resistivity, resistance to corrosive environments, low water and moisture permeability, and effective bond to steel surfaces, concrete and to common factory-applied coatings. Refer to Appendix B: Approved Products List for



# Technical Specifications and Standards for Construction of Sanitary Lift Station Systems

---

list of acceptable heat-activated sleeves.

## **L1300 PUMP AND MOTOR REQUIREMENTS**

### **L1301 PUMP AND MOTOR SIZING**

Pump station shall be capable of pumping the peak design flow with the largest pumping unit out of service. Pumps shall be capable of meeting all system hydraulic conditions without overloading the motors. In addition, a minimum of 3-hp motor shall be required unless prior arrangements have been approved by the City.

System head/pump capacity curves shall be prepared and submitted to the City along with the pump station plans. Such curves shall be based upon friction losses through discharge piping and force mains, and shall account for minor losses.

Determination of such friction loss shall be based on the Hazen-Williams Equation, the value for "C" shall be 120 for ductile iron pipe, 130 for PVC and 150 for HDPE. "C" values greater than 150 shall not be allowed. When initially installed, force mains may have a significantly higher "C" factor. The higher "C" factor should be considered only in calculating maximum power requirements and duty cycle time of the motor. Head capacity curves shall verify that the pumps are operating at peak efficiency and are suitable for the design flow applications. Pump and motor selection and head capacity curves shall reflect hydraulic conditions in cases where receiving force main systems are interconnected to additional pumping stations.

For pumping stations with a peak design flow of 1500 GPM or less, a minimum of two pump units shall be provided. Where the peak design flow exceeds 1500 GPM, three or more pump units shall be provided.

Developer's Engineer shall submit design calculations for all wastewater pump stations. Calculations shall include head capacity curves with copies of manufacturers pump curves, hydraulic analysis of force main systems, operating cycle calculations with wet well sizing, and buoyancy calculations. Pump impeller selection shall be based on a non-overloading factor in relation to the submitted pump curve.

### **L1302 PUMP EQUIPMENT DESIGN AND CONSTRUCTION**

The pumping equipment covered by these specifications is intended to be standard pumping equipment. The equipment furnished shall be designed, constructed, and installed in accordance with the best practices and methods, and shall operate satisfactorily when installed as shown on the Technical Detail A-502. Base elbows and pump guide rail systems shall be designed as an integral part of the specific pumping equipment to be used.

All necessary materials such as bolts, nuts, washers, and fasteners used to secure such pumping equipment for operation in accordance with the manufactures and the City specifications shall be furnished by the pump manufacturer or his designated representative and be of type 316 stainless steel. Brass or stainless steel nameplates giving the name of the manufacturer, voltage, phase, rated horsepower, speed, serial number, model number, impeller size and any other pertinent data shall be permanently attached to each pump. The nameplate rating of the motors shall not be exceeded. Pump suction and discharge openings shall be at least four (4) inches in diameter. The pump shall be capable of handling raw unscreened sewage with minimum three- (3)



inch diameter solid spheres.

## **L1302-1 PUMP CONSTRUCTION**

Major components shall be of gray cast iron, ASTM A-48, class 30B, with smooth surface devoid of blowholes or other irregularities. All exposed nuts or bolts shall be type 316 stainless steel construction. All metal surfaces coming into contact with the sewage, other than stainless steel or brass, shall be protected by a factory applied spray coating of acrylic dispersion zinc phosphate primer with a polyester resin paint finish on the exterior of the pump. Critical mating surfaces where watertight sealing is required shall be machined and fitted with nitrile or viton rubber O-rings. Fittings will be the result of controlled compression of rubber O-rings in two planes and O-ring contact of four sides without the requirement of a specific torque limit. Rectangular cross-sectioned gaskets requiring specific torque limits to achieve compression shall not be considered as adequate or equal. No secondary sealing compounds, elliptical O-rings, grease or other devices shall be used.

## **L1302-2 COOLING SYSTEM (DRY PIT INSTALLATION)**

Each unit shall be provided with an adequately designed cooling system. The cooling jacket shall encircle the stator housing, thus providing heat dissipation for the motor regardless of the type of installation. Impeller back vanes shall provide the necessary circulation of the cooling liquid through the water jacket. The cooling media channels and ports shall be non-clogging by virtue of their dimensions. The cooling system shall provide for continuous pump operation in liquid temperature of up to 104 degrees F. Restrictions below this temperature are not acceptable.

The cooling system may alternately be an internally circulated cooling design such that the coolant is either circulated through the motor or through the jacket surrounding the motor depending upon the model specified. The cooling system shall be capable of continuous operation at reduced speed without clogging or allowing the motor to overheat.

## **L1302-3 CABLE ENTRY SEAL**

The cable entry seal shall preclude specific torque requirements to insure a watertight and submersible seal. The cable entry shall consist of a single cylindrical elastomer grommet, flanked by washers, all having a close tolerance fit against the cable outside diameter and compressed by the body containing a strain relief function, separate from the function of sealing the cable. The assembly shall provide ease of changing the cable, when necessary, using the same entry seal.

The cable entry lead connection chamber shall be isolated from the interior/motor to prevent foreign material from gaining access through the pump top.

## **L1302-4 MOTOR**

The pump motor shall be induction type with a squirrel cage rotor, shell type design, housed in an air-filled (or food-grade glycerin-filled) watertight chamber, NEMA B type. The stator windings and stator leads shall be insulated with moisture resistant Class F insulation rated for 155 degrees C (311 degrees F).

The stator shall be dipped and baked three times in Class F varnish and shall be heat-shrink fitted into the stator housing. The use of bolts, pins, or other fastening devices



## Technical Specifications and Standards for Construction of Sanitary Lift Station Systems

---

requiring penetration of the stator housing is not acceptable. The motor shall be designed for continuous duty handling pumped media of (40 degrees C) (104 degrees F) and capable of up to ten (10) evenly spaced starts per hour.

The rotor bars and short circuit rings shall be made of cast aluminum. Thermal switches set to open at 125 degrees C (260 degrees F) shall be embedded in the stator coils to monitor the temperature of each phase winding. These thermal switches shall be used in conjunction with and supplemental to external motor overload protection and shall be connected to the control panel. The junction chamber containing the terminal block shall be hermetically sealed from the motor by an elastomer O-ring seal. Connection between the cable conductors and stator leads shall be made with threaded compression type binding posts permanently affixed to a terminal board. Wire nuts or crimping type connection devices are not acceptable.

The motor and pump shall be designed and assembled by the same manufacturer. The combined service factor (combined effect of voltage, frequency and specific gravity) shall be a minimum of 1.15.

The motor shall have a voltage tolerance of plus or minus 10%. The motor shall be designed for operation up to 40 degrees C (104 degrees F) ambient and with a temperature rise not to exceed 80 degrees C. A performance chart shall be provided showing curves for capacity, torque, current, power factor, input-output power (kW), and efficiency. This chart shall also include data on starting and no-load characteristics. The power cable shall be sized according to the NEC and ICEA standards and shall be of sufficient length to reach the junction box without the need of any splices. The outer jacket of the cable shall be oil-resistant SPC. The motor and cable shall be capable of continuous submergence under water without loss of watertight integrity to a depth of 65 feet. The motor horsepower shall be adequate so that the pump is non-overloading throughout the entire pump performance curve from shutoff through runout.

### **L1302-5 BEARINGS**

The pump shaft shall rotate on two bearings. Motor bearings shall be either permanently grease-lubricated or continuous oil bath. The upper bearing shall be a single row roller bearing.

The lower bearing shall be a two-row angular contact bearing to compensate for axial thrust and radial forces. Single-row lower bearings are not acceptable.

### **L1302-6 MECHANICAL SEAL**

Each pump shall be provided with a tandem mechanical shaft seal system consisting of two totally independent seal assemblies. The seals shall operate in a lubricant reservoir that hydrodynamically lubricates the lapped seal faces at a constant rate. The lower, primary seal unit, located between the pump and the lubricant chamber, shall contain one stationary and one positively driven rotating tungsten-carbide or silicon carbide vs. silicon carbide rings.

The upper, secondary seal unit, located between the pump and the lubricant chamber and the motor housing, shall contain one stationary tungsten-carbide seal ring and one positively driven rotating tungsten carbide or silicon carbide vs. silicon carbide seal rings. Each seal interface shall be held in contact by its own spring system. The seals



## Technical Specifications and Standards for Construction of Sanitary Lift Station Systems

---

shall require neither maintenance nor adjustment nor depend on direction of rotation for sealing. The following seal types shall not be considered acceptable nor equal to the dual independent seal specified: conventional double mechanical seals containing either a common single or double spring acting between the upper and lower seal faces.

No system requiring a pressure differential to offset pressure to affect sealing shall be used. Each pump shall be provided with a lubricant chamber for the shaft sealing system. The lubricant chamber shall be designed to prevent overfilling and to provide lubricant expansion capacity. The drain and inspection plug, with positive anti-leak seal shall be easily accessible from the outside. The seal system shall not rely upon the pumped media for lubrication. The motor shall be able to operate dry without damage while pumping under load. Seal lubricant shall be FDA approved non-toxic.

### **L1302-7 PUMP SHAFT**

Pump and motor shaft shall be the same unit. The pump shaft is an extension of the motor shaft. Couplings shall not be acceptable. The pump shaft shall be of type 420 stainless steel or type 329 stainless steel.

### **L1302-8 IMPELLER**

The impeller(s) shall be of gray cast iron, Class 30B, dynamically balanced, double-shrouded non-clogging design having a long throughlet without acute turns. The impeller(s) shall be capable of handling solids, fibrous materials, heavy sludge and other matter found in wastewater. Recessed Vortex impellers shall be allowed and are required for all stations discharging into a receiving manhole and on stations with tie-in pressures 10 psig or less. Mass moment of inertia calculations shall be provided by the pump manufacturer upon request. Impeller(s) shall be keyed to the shaft, retained with an expansion ring, and shall be capable of passing a minimum three- (3) inch diameter solid. All impellers shall be coated with an acrylic dispersion zinc phosphate primer.

### **L1302-9 WEAR RINGS**

A wear ring system shall be used to provide efficient sealing between the volute and suction inlet of the impeller.

Each pump shall be equipped with a nitrite rubber coated steel ring insert that is drive fitted to the volute inlet. This pump shall also have a stainless steel impeller wear ring heat-shrink fitted onto the suction inlet of the impeller.

### **L1302-10 VOLUTE**

Pump volute(s) shall be single-piece gray cast iron, Class 30B, non-concentric design with smooth passages large enough to pass any solids that may enter the impeller.

### **L1302-11 PROTECTION**

All stators shall incorporate thermal switches in series to monitor the temperature or each phase winding. At 125 degrees C (260 degrees F) the thermal switches shall open, stop the motor, and activate an alarm.

### **L1302-12 PUMP OPERATION**

Pumps shall be controlled automatically by means of a bubbler system. A float-type liquid



## Technical Specifications and Standards for Construction of Sanitary Lift Station Systems

---

level sensors in the wet well shall be constructed as back up. These sensors shall be of the Roto-Float type and as specified in Appendix B: Approved Product List.

### **L1303 PLACEMENT OF PUMP EQUIPMENT**

Pumps shall be mounted in the wet well as shown in Technical Detail A-502. Pumps shall be readily removable and replaceable without dewatering wet well or disconnecting any piping in wet well. The pump(s) shall automatically connect to discharge elbows when lowered into place on a dual stainless steel two-inch (2") guide rail system requiring no bolts, nuts, or fasteners to affect proper sealing. Mating of the pump discharge flange and base elbow face shall be accomplished by a simple linear downward motion of the pump and shall utilize O-rings or gaskets to accomplish sealing of the pump discharge flange and base elbow flange mating surfaces.

Each guide rail system shall consist of two (2) two-inch (2") stainless steel guide rails supported at the top by a stainless steel upper guide bracket and at the bottom by the discharge elbow. Ease and quick removal of pumps shall be a requirement of the system. Contractor will be responsible for demonstration of pump removal at City's request.

No portion of the pump shall bear directly on the floor of the wet well and no rotary motion of the pump shall be required for sealing.

Each pump shall be fitted with a type 316 stainless steel lifting bail with a grip system for removal of pumps; Guide rail system will be all stainless steel. Base elbow shall be anchored to the wet well floor with type 304 stainless steel anchor J-bolts set six inches (6") into concrete. J-bolts shall be hooked under reinforcing steel. Minimum of six inches (6") concrete shall be poured in bottom of wet well after centerline of access cover is determined. Reinforcing steel to be placed as indicated on Technical Detail A-502. Mounting of pumps and required inverts for proper pump operation shall be designed and constructed to meet manufacturer's requirements.

### **L1304 PUMP EQUIPMENT WARRANTY, PARTS AND SERVICE**

The pump manufacturer shall warrant pumping equipment being supplied to the City against defects in workmanship and material for a period of five (5) years.

The following replacement components and pump repair parts shall be considered normal stock items that are readily available and located within 100 mile radius of the City.

- Inspection Plug Washers
- Upper Mechanical Seal
- Lower Mechanical Seal
- Impeller Key
- Impeller Bolt
- Wear Rings
- Motor Cable
- Upper Bearing





## Technical Specifications and Standards for Construction of Sanitary Lift Station Systems

---

- Lower Bearing
- Cable Entry Washer/Grommet
- Complete Set of “O” Rings

The pump supplier will furnish the City with a notarized statement that the parts are in stock.

This statement will be provided, together with submittal drawings subject to the City's approval. If specified parts are not available when requested by the City, the pump supplier will provide at no additional cost to the owner, a pump to maintain the station in operation, or will reimburse the owner for equipment rental charges he must pay to maintain the operation of his station. Replacement and/or repair parts as well as factory certified service shall be made available 24 hours per day, seven (7) days per week including holidays. This service shall be able, if requested to respond on site within six (6) hours of initial contact.

“Loaner” pumps shall be available to City at no charge if pumping equipment is under warranty and at a fair and reasonable charge if pumping equipment is out of warranty. “Loaner” pump shall be made available for City pick up or delivered if requested to City within six (6) hours of initial contact.

### **L1305 PUMP STATION PIPE, VALVES, AND FITTINGS**

Each pump shall have separate discharge line from base elbow in wet well and through valve vault to a point three-feet (3') past exterior of discharge side of valve vault.

Discharge piping and fittings, unless otherwise stated, shall be HDPE conforming to AWWA C906 ASTM D3350 DR11, with continuous green striping. HDPE piping within wet well shall be butt-fused. Outside of the wet well, all pipe, valves, and fittings, unless otherwise stated, shall have flange ends. All bolts, nuts, and washers used to connect the flange ends shall be of type 316 Stainless Steel. The discharge piping shall be a minimum of four-inch (4") in size.

All pipe valves and fittings shall be installed, as indicated in Technical Details A-502, A-503, and A-504. Each vertical discharge pipe in wet well shall be of one piece, continuous length. If depth in wet well does not permit this, additional lengths shall be approved by City. Under no condition shall adapter flanges be permitted in wet well. Each horizontal discharge pipe shall be of one piece continuous length from connection with 90 degree bend in wet well to connection within valve vault.

### **L1305-1 DISCHARGE VALVES**

Spring and lever or weighted lever swing check valves shall be manufactured from gray cast iron meeting or exceeding ASTM A126 grade B. Valves to comply with AWWA C 508 latest revision, and as listed in Appendix B: Approved Products List.

Discharge valves shall be resilient seat gate valve or full-port plug valve, both with type 316 stainless steel fasteners, as specified in Appendix B: Approved Products List. Gate valve shall be manufactured to meet or exceed the requirements of ANSI/AWWA C- 515, latest revision. All internal and external ferrous surfaces of the valve, including the interior, shall have Thermo setting bonded epoxy coating with a minimum thickness of 10 mils. Coating to be applied to castings prior to assembly to insure all exposed areas, including bolt holes



## Technical Specifications and Standards for Construction of Sanitary Lift Station Systems

---

and flange face surfaces, will be covered. Contractor shall furnish written certification of valve coatings from manufacturer.

### **L1305-2 EMERGENCY PUMP BY-PASS CONNECTION**

Connection shall be four-inch (4") or six-inch (6") depending on station size. This will be determined by City. Connection to include gate valve, adapter flange with quick disconnect male fitting-part #FLA Cam and Groove with dust cap. Emergency pump bypass shall be installed as indicated on Technical Details.

### **L1305-3 PRESSURE TRANSDUCERS**

Pressure transducer shall be installed with stainless steel nipple and ¼ stainless steel ball valve on each check valve as indicated in Technical Detail A-504. Pressure transducer shall match pump curve and force main pressures. Transducer shall be all stainless steel construction with ¼" NPT male connection; wiring shall be 50ft of shield cable. Pressure transducer shall not be installed until after the substantial completion date unless otherwise requested by the City. Refer to Appendix B: Approved Products List for list of acceptable pressure transducers.

### **L1305-4 FIELD PAINTING**

All non-HDPE pipe, valves, and fittings within valve vault, and vault walls and floor, shall receive, after installation, one 3-mil coat white primer with one 3-mil coat gray coating. See Appendix B: Approved Products List for acceptable coatings.

### **L1305-5 CERTIFICATION OF GRADE**

The Contractor shall furnish written notarized "Certification of Grade" from supplier or manufacturer of all equipment, fittings, or parts required to be 316 stainless steel.

### **L1306 PUMP STATION WATER SYSTEM**

All wastewater pump stations shall be provided with a water system of adequate capacity and pressure for station wash down and other requirements. The station water system shall be completely separated from the potable water supply by means of a reduced pressure type backflow preventer or other City approved system. Water system to be installed as indicated in Technical Detail A-506, and shall end with a ¾ inch hose bib. Top of meter box shall be set two inches (2") above finished grade.

### **L1307 PUMP STATION STAND-BY POWER GENERATOR**

All lift stations to be operated and maintained by the City shall be constructed with a stand-by generator.

#### **L1307-1 GENERATOR REQUIREMENTS**

- Directly connected to the engine flywheel housing with flex coupling
- Generator shall meet performance class G3 of IEC
- Unit shall be in compliance with UL2200 labeled.

#### **L1307-2 ENGINE**

- Water-cooled diesel engine, sized for generator set



# Technical Specifications and Standards for Construction of Sanitary Lift Station Systems

---

- Emission compliant engine

## **L1307-3 CONTROLS**

- Solid state, microprocessor based generator controls
- Controls shall provide all operating, monitoring and control functions for generator set

## **L1307-3 ENCLOSURE/SILENCER**

- Complete diesel engine generator set including control panel, engine starting batteries and fuel oil tank shall be enclosed in a factory assembled water protective, sound-attenuated enclosure
- Critical grade silencer
- Companion flanges
- Flexible stainless steel exhaust
- All aluminum enclosure panels and frame
- Enclosure locks

## **L1307-4 FUEL TANK**

- Double wall sub-base tank integral to enclosure
- 24 hour capacity at 100% full load
- Rupture basin with 110% capacity
- Locking fuel caps
- Low fuel alarm contact
- Fuel tank rupture alarm contact
- Must meet UL142 and FDEP standards
- Tank to be coated with Line X or City-approved equal coating

## **L1307-5 BATTERY CHARGER**

- Current limiting charger to automatically charge batteries
- Charger shall be dual charge rate with automatic switching to boost rate when required
- Charger must be mounted on packaged generator

## **L1307-6 START-UP AND TESTING**

- Vendor must coordinate all start up and testing activities with the engineer and owner. After installation is completed by others and normal power is available, the vendor must perform a one day start-up including the use of building load. The start-up technician will instruct all necessary personnel how to operate and maintain the equipment in accordance to the manufacturer's requirements.



# Technical Specifications and Standards for Construction of Sanitary Lift Station Systems

---

## **L1307-7 CONDITIONS**

- In addition to equipment specified, each generator shall be equipped with all standard equipment as specified by the manufacturer for this model and shall include but not limited to the following necessary items:
  - a. Initial filling of oil and antifreeze
  - b. Shrink wrap applied to the product to ensure a clean finish

## **L1307-8 START-UP AND SUBMITTALS**

During startup, the technician shall record the following information and provide to the owner for his records

- Record operating voltage, frequency, phase and connected load (amperage)
- Package information consisting of generator make, model, serial number of complete package and start-up date
- Record engine and generator serial numbers
- One complete set of operation and maintenance manuals
- Two year or 1,500-hour standard generator warranty. Labor, materials, and travel for the warranty period repair will be paid by manufacturer during normal business hours.

## **L1307-9 AUTOMATIC TRANSFER SWITCH**

- Open transition (break-before-make) transfer logic
- Transfer switch must meet the related industry standards
- UL-1008-Automatic transfer switches for use in emergency systems
- CSA-Automatic Transfer Switches
- NEMA- Industrial control systems AC transfer switch equipment
- IEC-Automatic transfer switching equipment
- Automatic transfer switch must have a neutral position.
- Mounting frame for enclosure must be stainless steel

## **L1307-10 RATING**

Automatic transfer switch enclosure, with stainless steel mounting frame, must be NEMA 3r stainless steel.

## **L1307-11 FUNCTIONAL**

- The automatic transfer switch shall automatically transfer the load to the generator supply in the event of a utility supply failure and return the load to the utility supply upon restoration. The automatic transfer switch power switching devices shall be mechanically and electrically interlocked to prevent the utility and generator supplies from being interconnected.
- All timers should be field adjustable to ensure proper field site compatibility.



# Technical Specifications and Standards for Construction of Sanitary Lift Station Systems

---

## **L1500 PUMP STATION ELECTRICAL POWER AND CONTROL SYSTEMS**

This subsection specifies the electrical power and duplex control system. These requirements for wastewater pump stations requirements apply when two or more pumps are involved except for the quantity of control equipment and panel size shall be increased accordingly. At all locations which require pump motors to be sized **larger** than 10 hp., a “soft start controller”, will be provided for each pump to reduce inrush currents and ramp up motor to speed. See Appendix B: Approved Products List for acceptable soft starters. All equipment and materials shall be installed and permanently grounded in accordance with the requirements of the National Electrical Code (NEC). Driven ground rod, which has a resistance to ground of 25 OHMS or less, shall be augmented until the resistance to ground is 25 OHMS max. All cable and wire for feeders and branch wiring shall be copper type THW, or THWN. The contractor shall furnish all labor, materials, equipment, facilities, transportation and services required for furnishing, delivery, and installation of a complete workable electrical system.

### **L1501 ELECTRICAL CONNECTIONS**

Connections to motor leads and float control leads will be made outside the wet well. Conduit seals shall be used to prevent the atmosphere of the wet well from gaining access to the control center. Conduit seals to be located below control center provide stainless steel junction box for float control and motor leads located below conduit seals.

Conduit from wet well to junction box will be sealed with “duct seal putty.” Direct motor leads and float leads will not enter control panel. Type THHN, THWN (for motor loads), type TFFN (for control) copper wire, will be used from control panel to stainless steel junction boxes.

### **L1502 ELECTRICAL SERVICE**

Contractor shall provide new underground electrical service. All service equipment and installations shall be constructed to meet existing electrical conditions and requirements in the City’s lift stations system. Electrical services are required to match existing emergency generation systems and procedures.

All services shall be three-phase. The minimum allowable service size is 100-amp. Single-phase systems are not acceptable. Phase converters will not be accepted. The City will not accept a 208-volt three-phase system. Service shall provide sufficient power to effectively operate the applicable pumping station and all associated equipment. Size and number of pumps and associated equipment shall determine service amperage requirements. Service shall have three-phase surge protection on station main. Service shall be 240-volt, three-phase for motors 20 hp or smaller. Florida Power & Light’s (FPL) 208-volt high voltage leg (phase to neutral) will be located in the “C” position, far right and marked with orange tape. The “C” position will be used throughout the power system as “High Leg” including the control panel. 480-volt, three-phase power shall be provided for motors 20 hp or larger.

Connection to Florida Power & Light will be made at a hand hole installed by FPL. Contractor will provide all wire, conduit, and associated equipment to FPL point of connection. Contractor is responsible for all fees associated with the service installation as may be required by the electric utility, including temporary services. The contractor shall provide a NEMA 4X stainless steel (fused) main disconnect switch. Refer to Appendix B:



# Technical Specifications and Standards for Construction of Sanitary Lift Station Systems

---

Approved Products List.

## **L1503 CONSTRUCTION MATERIALS**

Due considerations shall be given to the selection of materials because of the presence of hydrogen sulfide and other corrosive gases, greases, oils, and other constituents frequently present in sewage. All mounting hardware (nuts, bolts, washers, etc.) shall be type 316 stainless steel. All enclosures and disconnects shall be type 304 stainless steel NEMA 4X water-tight with gasket. All enclosures and disconnects shall be lockable.

## **L1504 PIPE**

All exposed pipe shall be rigid galvanized steel pipe. All field cut steel pipe will have the threads cleaned and painted with cold galvanized paint.

All steel pipes below grade will be painted with black asphalt paint, to a point of six inches (6") above grade. This includes pipe from control panel to a point past first 90-degree ell fitting underground. PVC pipe from this point shall run to wet well to at least two inches (2") inside well, with a PVC pipe end bell bushing in wet well. PVC shall be gray electrical type schedule 40. All exterior locknuts will be the sealing type on all equipment. For pump motor power cables and control cables from control panel to wet well, the minimum conduit size shall be two-inch (2") diameter.

## **L1505 CONTROL-ELECTRICAL SERVICE MOUNTING**

Mounting rack shall be constructed of two-inch (2") diameter minimum, type 316 stainless steel tube, 11 gauge. Stainless steel strut channel (unistrut) one and one-half-inch (1½") minimum, mounted on type 316 three-inch (3") stainless steel pipe, may be used as alternate to tubing. Exposed pipe ends shall be closed with PVC plug caps of the proper size.

The control panel, main disconnect, meter, and junction boxes shall be mounted directly to the rack. All material and equipment to be level and plumb. All enclosures, junction boxes, fasteners, hinges, anchors, nuts, bolts, screws, washers, rivets, etc., shall be type 316 stainless steel unless otherwise specified.

## **L1506 CONTROL PANEL COMPONENTS**

Control panel shall be a stainless steel NEMA 4X enclosure, with aluminum dead front interior door. Enclosure will have a three-point latch system, operated with one common handle. All controls and wiring shall meet or exceed the requirement of the National Electric Code. All starters and breakers shall be sized for the motor loads and associated equipment.

Control panel shall include the following components:

Main breaker, Pump breakers, pump starters, overload protection devices, overload reset buttons, control breakers, emergency generator circuit breaker that includes mechanical interlock (or alternate method of positive isolation of electric power supply while generator circuit is active), control terminals, monitor terminals, 20-amp simplex receptacle for bubbler, duplex 120-volt outlet with ground fault circuit interrupter, phase monitor and bypass switch (480-volt systems), ground lugs, neutral block, thermal overload terminals, generator receptacle (3-phase exterior), power transformer (480-volt



## Technical Specifications and Standards for Construction of Sanitary Lift Station Systems

---

systems), soft start controllers, pump control unit, etc.

### **L1506-1 CONTROL PANEL ASSEMBLY**

The pump station control panel shall be completely factory-wired and shall have an isolated neutral buss bar. Each control circuit wire shall be numbered as indicated on the schematic. No concealed wiring shall be allowed. Each device in the control circuit shall be identified with the proper control circuit abbreviation. All wiring shall be shown on electrical schematic diagrams. A 10" x 12" stainless steel pocket for log sheet storage shall be permanently affixed to the interior side of the exterior door

An adhesive mylar copy of the schematic drawings and terminal diagram shall be permanently affixed to the inside of the control panel door. Both outer and inner dead front door will have "door stops" to hold in the open position. Panel will be equipped with an exhaust fan to remove generated heat. Control will be through internal thermostat.

### **L1506-2 APPROVED CONTROL EQUIPMENT MANUFACTURERS**

Refer to Technical Specifications and Standards Appendix B: Approved Products List.

### **L1507 LIFT STATION OPERATIONS**

The operation of the lift station will be based on a four-point control. In ascending order the four points are:

- low water cut-off level
- lead pump on level
- lag pump on level
- high water alarm level

The lead pump is energized when the sewage level reaches the lead pump on level. The lead pump shall operate continuously until the water level is lowered to the low water cut-off level. The lag pump shall be energized if the lead pump is incapable of handling the flow of sewage, allowing the water level to reach the lag pump on level. The lag pump shall then operate in unison with the lead pump until the water level is lowered to the low water cut-off level. At this time, both pumps are de-energized.

An automatic circuit shall alternate the lead pump-lag pump sequence on every pump-down cycle. A time delay relay shall be provided to prevent both lead and lag pumps from starting at the same time.

### **L1508 TCU OPERATION**

Station operation will be provided through the use of a telemetry control unit (TCU) as manufactured by Data Flow Systems, Inc. This unit, along with the Bus Extender Module (BEM), is required for interface with the existing telemetry system. Refer to Appendix B: Approved Products List for the TCU and BEM model numbers. No substitutes allowable. The interface for the existing Lift Station control/telemetry system will be the responsibility of the contractor. Data Flow Systems, Inc. will inspect and perform start-up for the control/telemetry system and Remote Terminal Unit (RTU).



## Technical Specifications and Standards for Construction of Sanitary Lift Station Systems

---

### **L1509      UL LABEL**

The control panel enclosure shall be in accordance with Underwriters Laboratories and must bear the manufacturer UL label for enclosures to indicate and qualify same.

### **L1510      MANUFACTURER NAMEPLATE**

A nameplate indicating the voltage, phase, horsepower, order reference number, date manufactured and the control panel manufacturer's name, address, and telephone number shall be permanently affixed to the inside of the enclosure door

### **L1511      WIRING**

All power wire shall be stranded copper and sized as required for load and application according to the National Electric Code (NEC). Electrical work shall be in accordance with the NEC latest edition and shall subject to all local codes. All control and signal wire shall be a minimum of no. 14 AWG, or shield cable, as necessary, 90-degree insulated and color-coded. Colors shall be red for all AC control, blue for all DC control, yellow for external source control, white for AC neutral, and green for equipment ground wiring. All wiring on the rear of the inner door shall be neatly bundled using tie wraps or other means. All internal wiring on the backplate shall be neatly routed in wire duct with removable covers. All wiring shall be continuous point-to-point (no splices) and shall be fully accessible with permanent number marking on each end to match the control schematic drawings.

### **L1512      QUALITY CONTROL AND TESTING**

The panel shall be manufactured using quality workmanship and components. Upon manufacturer's completion of the panel, it shall be completely factory-tested. All control and alarm operations shall be performed with external signals simulated to insure proper operation. The three-phase line voltage source for which the panel is intended shall be used for testing.

### **L1513      REMOTE TERMINAL UNIT (RTU)**

The control panel shall be capable of being monitored by existing City-operated radio telemetry system main terminal unit.

Contractor is responsible for installation of RTU, antenna, conduit, and wiring from RTU to control panel. The RTU shall be manufactured and installed by Data Flow Systems, Inc. of Melbourne, Florida. RTU will be Data Flow TAC II system or most recent version thereof. It is the responsibility of the Contractor to have Data Flow Systems, Inc. inspect and start-up RTU system. Contractor shall provide the City with a notice of two (2) working days prior to RTU start-up. A City representative shall be present at time of RTU start-up.

The RTU shall contain the RTU unit backplate, bus extender module (BEM), radio interface module (RIM), power supply module (PSM), battery, antenna, tower, cable, and all parts to provide a functioning telemetry system compatible with existing system. Refer to Appendix B: Approved Products List for the BEM, RIM, and PSM model numbers.





# Technical Specifications and Standards for Construction of Sanitary Lift Station Systems

---

## **L1514 ELECTRICAL GROUNDING SYSTEM**

A grounding system shall be installed as per National Electrical Code, local codes, and ordinances.

Submitted drawings shall clearly indicate materials and installation to construct a completely functional electrical grounding system. An underground perimeter cable grounding system shall be installed with bonded connections to at least the following equipment:

- Wet Well Cover
- Valve Vault Cover
- Control Panel Mounting Rack
- Main Disconnect Switch
- Fence
- Telemetry Antenna Tower

A type 316 stainless steel stranded cable 7/16 inches in diameter shall be fabricated through top slabs of wet well and valve vault at foundry and connected to the access hatch frames by way of an approved stainless steel mechanical connection. The stainless steel cable shall be connected to the copper electrical grounding system below grade. See Technical Details A-505. Under no circumstances shall access hatch ground wires be allowed to run across outside top slabs.

## **L1600 REQUIRED SUBMITTALS FOR PUMP STATIONS**

Electronic pdf submittals shall be provided to the City along with the required as-built drawings at construction completion. Pump station submittals shall include the following:

- 1) Shop drawings showing all-important details of pre-cast construction, dimensions, and anchor bolt locations.
- 2) Pre-cast coating specifications and warranty information.
- 3) Descriptive literature, product sheets, bulletins, and/or catalogs of equipment.
- 4) Data on the characteristics and performance of each pump. Data shall include guaranteed performance curves based on actual shop tests of similar units, which demonstrates that pumps meet the specified requirements for head, capacity, efficiency, submergence, and horsepower.
- 5) Curves plotted from no flow at shut-off head to maximum manufacturer recommended pump capacity. Catalog sheets showing a family of curves will not be acceptable.
- 6) Complete layouts, wiring diagrams, telemetry or control schematics, including coordination with other electrical control devices operation in conjunction with the pump control system.
- 7) Suitable outline drawings shall be furnished for approval before proceeding with manufacture of any equipment. Standard reprinted sheets or drawings simply marked to indicate applicability may not be acceptable.



## Technical Specifications and Standards for Construction of Sanitary Lift Station Systems

---

- 8) A drawing showing the layout of the pump control panel shall be furnished. The layout shall indicate all devices mounted on the door and in the panel and shall be completely identified.
- 9) The weight of each pump.
- 10) Complete motor data shall be submitted including:
  - a) Nameplate identification
  - b) No-load current
  - c) Full load current
  - d) Full load efficiency
  - e) Locked rotor current
  - f) High potential test data
  - g) Bearing inspection report
- 11) All other data as required in this SECTION.

### **L1700 INSPECTION AND START-UP TESTING**

A factory representative knowledgeable in pump operation and maintenance shall inspect and supervise a start-up test at the pumping station covered by this section. A minimum of one (1) working day shall be provided for the inspections. Additional time made necessary by faulty or incomplete work or equipment malfunctions shall be provided as necessary to meet the requirements in this section at no additional cost to the City. Upon satisfactory completion of the start-up test, the factory representative shall issue the required manufacturer's certificate.

The start-up test shall demonstrate that all items of this section have been met by the equipment as installed and shall include, but not be limited to, the following tests:

- That all units have been properly installed.
- That the units operate without overheating or overloading any parts and without objectionable vibration.
- That there are no mechanical defects in any of the parts.
- That the pumps can deliver the specified pressure and quantity.
- That the pumps are capable of pumping the specified material.
- That the pump controls perform satisfactorily.

### **L1800 WASTEWATER PUMP STATIONS NOT ACCEPTED BY CITY**

All Owners and/or Developers who intend to construct wastewater pump stations that are NOT ACCEPTED BY THE CITY yet intend to discharge into the City wastewater collection system shall make access available to the City for such stations in the event of an emergency. The City shall have the right to deny pump station discharge into its wastewater collection system if access to pump station is ever denied. Pump station discharge service shall be single piping run until tie-in point with City system. Service connection to City wastewater collection system shall have isolation valve installed for



## Technical Specifications and Standards for Construction of Sanitary Lift Station Systems

---

maintenance purposes. The valve shall be located at or close to owners' property line.

Pump station will be equipped with emergency generator connection. See Section L1506-2 for acceptable generator receptacles.

Pump station shall be equipped with emergency pump by-pass connection compatible with Section L1305-2 and Technical Details A-502 and A-503.

Prior to date of acceptance of discharge into City collection system, owner shall provide name, address, and phone number of two persons or company responsible for all emergency responses to the facility. These contacts shall be available 24 hour per day, seven (7) day a week to accept emergency calls. This contact information shall be posted on the front exterior of the control panel by means of a permanent phenolic label.

### **L1900      INSTALLATION GUIDE**

This section serves only as an aid to clarify what services and/or equipment is normally and customarily furnished during the installation of a City-accepted lift station. The Developer of Record is ultimately and solely responsible for the delegation and/or coordination of work, equipment, and materials required to construct and install the lift station. The lift station shall be constructed and installed in accordance with these specifications prior to City acceptance.

The scope of work and materials/equipment provided is divided into five areas as follows:

The pump and control panel supplier typically furnishes the duplex submersible pump package and the associated control panel. This includes, but is not necessarily limited to, the following items:

- (2) submersible sewage pumps and adequately-sized motor cables
- (2) discharge elbows with anchor bolts
- (2) sets of stainless steel guide rails and associated guide rail brackets
- (4) Roto floats and associated float brackets
- (1) set of aluminum hatch covers for wet well and valve vault
- (2) stainless steel lifting cable chain and associated hardware
- (1) control panel and component package which includes Data Flow Systems Pump Control Unit (PCU) and unattached generator receptacle.
- (1) start up services and manufacturer's acceptance of pump and panel installation as it pertains to pump and panel warranties (this includes all pertinent manuals and printed warranty information)

The telemetry system manufacturer typically furnishes and installs the telemetry panel and associated components which includes but is not necessarily limited to the following:

- Telemetry control panel box
- Printed circuit cards



## Technical Specifications and Standards for Construction of Sanitary Lift Station Systems

---

- Uninterrupted power source unit
- Radio unit set at required frequency
- Antenna with tower
- Electrical grounding components and connection between antenna and telemetry panel
- Conduit and control wires between telemetry panel and lift station control panel
- Startup services and manufacturer's acceptance of telemetry system as it pertains to telemetry warranties (this includes all pertinent manuals and printed warranty information)

The subcontractor (electrical) usually, but not necessarily, furnishes and installs the following:

- Applicable electrical construction permits
- Stainless steel mounting rack for control panel and main disconnect
- Meter can and conduits as per FP&L requirements
- Electrical and float conduits and cables between control panel and wet well
- Connect motor cables and float cables to panel
- Control panel grounding system, (including connection to site fencing)

The underground contractor usually, but not necessarily, furnishes and installs the following:

- Wet Well (including all associated concrete invert work)
- Valve Vault (including drain piping)
- Potable water service (including backflow prevention device)
- All piping, valves, and associated fittings, etc., between base elbows and force main tie-in
- Installation of base elbows, guide rails, float brackets, and submersible pumps

The developer of record usually, but not necessarily, furnishes and installs the following:

- Site grading, ground cover (including required concrete work) and landscaping
- Site fencing and driveway (including sidewalk, if required)
- Construction and/or potable water meter

### **L2000 FINAL CLEAN-UP**

Upon completion of the work and before acceptance by the City, the Contractor shall remove all debris, complete sodding, sprigging or seeding if required by the plans, and shall leave all areas affected by his operations in a neat and presentable condition.

A release must be signed by owners of private property that the Contractor used for storage or equipment, materials, vehicles, etc., releasing the City from any liability.



## Technical Specifications and Standards for Construction of Sanitary Lift Station Systems

---

Release must be submitted prior to issuance of certificate of completion.

### **L2100 AS-BUILT SURVEY**

Overall Utility layouts (AutoCAD drawings) must be in real-world GPS state plane coordinates – NAD 1983 HARN State Plane Florida East FIPS 0901. State Plane Coordinates shall be labeled and shown on a minimum of four (4) reference, right-of-way, or property corner monuments shown on the Construction Plans that remain in their original condition after construction has been completed.

Record drawings depicting the as-built conditions of the project are required for all utility systems being accepted by the City. Record drawings shall consist of the construction plans as prepared by the Engineer of Record and approved by the City, revised to include the information provided by the as-built survey along with any additional deviations from the original design drawings as deemed appropriate by the Engineer of Record. The as-built survey must be prepared by a surveyor registered in the State of Florida and shall contain the following information:

- At least two (2) horizontal ties and one (1) vertical tie to all manholes, sewer lateral/main wyes, sewer lateral terminations, force main valves, and all force main fittings that delineate change of either horizontal and or vertical direction. These ties are to be from permanent point such as property corners, curbs, pavement intersections etc. An acceptable station and offset system may also be utilized.
- Location of mains from property or easement lines and alignment distance from centerline of road at 50-foot intervals.
- Conflict crossing details, including depths of each utility at crossing, and separation provided between utilities.
- Size and type of wastewater main material for each run of pipe and at any material change and distance of mains from buildings or structures within 10 feet of the wastewater main.
- Distance of wastewater main from manhole to manhole, distance from downstream manhole to each sewer lateral/main wye, finished invert and manhole rim elevations, and sewer lateral terminating end elevations.
- Pertinent easement information, including official record book and page number, width of easement, and distance from wastewater main to sides of easement.
- Note City's point of acceptance on as-built.
- Note all private utility systems on as-built.
- A certification by the surveyor/engineer accepting responsibility for accuracy of information supplied on the as-built drawings and a statement that all mains are within easements and/or public right-of-ways.

As-builts shall be drawn at an engineering scale of 1 inch = 50 feet maximum. Areas requiring additional detail may be enlarged as necessary. Right of way, easements and lot lines shall be accurately shown. Lot and block numbers and street names shall be included.

The City will review the draft as-built set and issue comments requiring revisions/corrective



## Technical Specifications and Standards for Construction of Sanitary Lift Station Systems

---

actions to be made by the as-built surveyor. Revisions shall then be made and a revised drawing set shall be resubmitted for City review. In this manner, a final as-built drawing set will ultimately be reached which will then be approved by the City.

After the surveyor has certified the approved as-built survey, the Engineer of Record shall submit the FDEP Request to Place Domestic Wastewater Collection System into Operation to close out the wastewater permit. The Engineer of Record will certify that the system depicted on the as-built was constructed in substantial conformance with approved plans and will function as intended.

Three (3) final-approved signed/sealed as-built sets, as well as a digital copy shall be submitted to the City in AutoCAD (dwg) format on a disc, complete with plot (ctb) file and any other drawings referenced in the main as-built dwg file.

### **L2200 REQUIREMENTS FOR SCHEDULING PRE-FINAL INSPECTION**

After all items pertaining to project have been completed and checked by contractor/developer, notify Engineering Department to establish date for pre-final inspection.

There are several criteria that developers must meet prior to the City's scheduling a pre-final inspection for any development project or wastewater collection system project. The criteria are:

1. A draft as-built set is required to be submitted to the City Engineering Department a minimum of two (2) working days prior to the scheduled pre-final inspection date. Either electronic pdf or hard copy is acceptable. This time frame allows for distribution of the drawings to the appropriate City departments/divisions that will eventually operate and maintain the improvements. City staff must have time to review the drawings and to confirm that the data shown is accurate. Note that a pre-final inspection will only be scheduled by the City after receiving the draft as-built set.
2. The City must receive satisfactory results for the pressure test on new sewer force main lines. If the lines do not pass the test, the project is not ready for an inspection. In addition, the video inspection of the gravity sewer must be received and approved by the Wastewater Collection Division.
3. The City should receive the punch list, which has been incorporated into this section. The purpose of the pre-final inspection is to determine if the project is complete and if the work is acceptable.
4. The purpose is not to inspect a partially completed project and provide the developer a list of things he/she must do to complete it. In short, the project should be complete. The punch list, checked off by the developer, will indicate to the City that the project is completed in the developer's opinion.
5. The contact for scheduling the pre-final inspection is the City Engineering Inspector who has been assigned to your project.

During the Pre-final inspection, the items listed in Table L2200-1 will be checked.



## Technical Specifications and Standards for Construction of Sanitary Lift Station Systems

TABLE L2200-1		
SANITARY LIFT STATION PRE-FINAL PUNCH LIST		√
Manholes or Wells		
1	Ring and cover specified O.R.S. type.	
2	Manhole must not show any leakage.	
3	Ramneck trimmed and seams grouted.	
4	Invert properly constructed at proper grade.	
5	Adjustment brick grouted and painted.	
6	Manhole interior properly painted.	
7	Liner or coating installed if required.	
8	Manhole ring and cover even with grade of asphalt.	
Force Mains		
9	Discharge end at manhole at 180° of invert outfall pipe.	
10	Valve box lids stamped “sewer”, painted green, with 24” x 24” x 6” concrete pad.	
11	Electronic markers installed per Section S1409, City Technical Specifications and Standards for Wastewater Collection Systems	

### **L2300 MAINTENANCE BOND**

A two-year maintenance bond is required on all projects. This bond can be a cash or paper bond. This bond is for the dedicated portion of the work only. The bond is 10% or a minimum of \$1,000.00 whichever is greater.

At the end of the two-year maintenance bond period the following items will be checked.

TABLE L2300-1		
SANITARY LIFT STATION MAINTENANCE BOND PUNCH LIST		√
1	City will pump down wet well to expose interior surfaces. Structures will be washed to remove surface buildup. Inspection of coating or lining will be made for deficiencies, i.e. cracks, leaks and bulges.	
2	All piping, plumbing, tops, vents, structures, substructures, control, telemetry, electrical equipment, fencing, site drainage and landscaping will be inspected.	

# Technical Specifications and Standards for Lift Stations Appendix A- Technical Detail Drawings



LIFT STATION NOTES:

1. ALL EXPOSED METAL SHALL BE COATED IN ACCORDANCE WITH SECTION L.9.4.
2. VALVE VAULT SHALL BE COATED WITH COAL TAR INSIDE & OUT IN ACCORDANCE SECTION L 0.50.
3. WET WELL & RECEIVING MANHOLE SHALL BE LINED SEE APPENDEX B: APPROVED PRODUCTS LIST.
4. BASE AND FIRST RISER UNIT SHALL BE CAST MONOLITHIC.
5. WALL PENETRATIONS IN WET WELL OR VALVE VAULT SHALL BE MADE WATERTIGHT WALL SLEEVE OR NON-SHRINK GROUT
6. THERE SHALL BE NO VALVES OR ELECTRICAL JUNCTION BOXES IN WET WELL
7. WET WELL AND VALVE VAULT COVERS SHALL BE ALUMINUM WITH 316 S.S. HARDWARE AND LOCK SET
8. DOORS ON WET WELL AND VALVE VAULT TO BE GROUNDED. TYPE 316 STAINLESS STEEL CABLE FABRICATED INTO STRUCTURE TOP SLAB OF WET WELL AND VALVE VAULT AT FOUNDRY. STAINLESS STEEL-TO-COPPER UNION TO BE BELOW GRADE OUTSIDE OF STRUCTURE TOP SLABS.
9. FLEXIBLE COUPLING SHALL BE SLEEVE TYPE.
10. PUMP DISCHARGE PIPES WITHIN THE WET WELL SHALL BE HDPE WITH HDPE FLANGED OR BUTT-FUSED FITTINGS
11. ALL HARDWARE IN WET WELL AND VALVE BOX SHALL BE STAINLESS STEEL
12. EMERGENCY PUMP CONNECTION SHALL BE LOCATED NEXT TO ASPHALT ACCESS ROAD, SEE INDIVIDUAL PUMP STATION SITE PLANS FOR LOCATION.
13. SEE SPECIFICATION DRAWING BOX -A-113 & A-115 LID PAINTED "GREEN" NOT BLUE."
14. UNIT SHALL BE CAST MONOLITHICLY FOR 6' I.D. LIFT STATIONS; LARGER DIAMETER STATIONS SHALL HAVE PROVISIONS TO ENSURE WATER TIGHT JOINT BETWEEN BASE AND FIRST RISER, SUCH AS A WATER STOP OR TONGUE AND GROOVE JOINT.
15. SHRINKING GROUT, EMBECO OR APPROVED EQUAL.
16. ANCHOR BOLTS SHALL BE TYPE 304 STAINLESS STEEL " J " BOLTS SET 6" INTO CONCRETE. " J " BOLTS SHALL BE HOOKED UNDER REINFORCING STEEL.
17. 6" LAYER OF CONCRETE SHALL BE POURED AFTER CENTER LINE OF ACCESS COVER IS DETERMINED. CONTRACTOR SHALL SET ANCHOR BOLT LOCATION 13" OFF CENTER LINE OF ACCESS COVER. SUMP SHALL BE SHAPED PER PUMP MANUFACTURES REQUIREMENTS
18. VENT PIPE TO BE FLANGED BY PLAIN END 4" CLASS 53 DUCTILE IRON,WITH TWO 4"90° DEGREE DUCTILE IRON BENDS TO BE INSTALLED AS SHOWN ON STANDARD DRAWING. COURSE STAINLESS STEEL SCREEN TO BE PLACED OVER OPEN END OF LAST 90° FLANGE ALL NUTS, BOLTS AND WASHERS USED TO CONSTRUCT WET WELL VENT SHALL BE TYPE 304 STAINLESS STEEL .WET WELL VENT TO BE PAINTED AS PER VALVE VAULT PIPING SPECIFICATIONS STATED IN SUB - SECTION X . 10 AQUAPOXY GREY.

M I N I M U M S			
STATION DIAMETER	CONCRETE THICKNESS		
	WALL	BASE	TOP OF SLAB
6'	8"	12"	10"
8'	9"	12"	10"
10'	10"	15"	12"

**LIFT STATION NOTES**

REV:	REV: BY	<b>CITY OF MELBOURNE UTILITIES ADMINISTRATION</b>	SCALE: N.T.S.
DATE: 7/15/20	JOB NO.:		DWG NO. A-500
DRAWN BY:	DSGN. BY		

**NOTE:**

TELEMETRY ANTENNA TO BE LOCATED WITHIN THE FENCED AREA

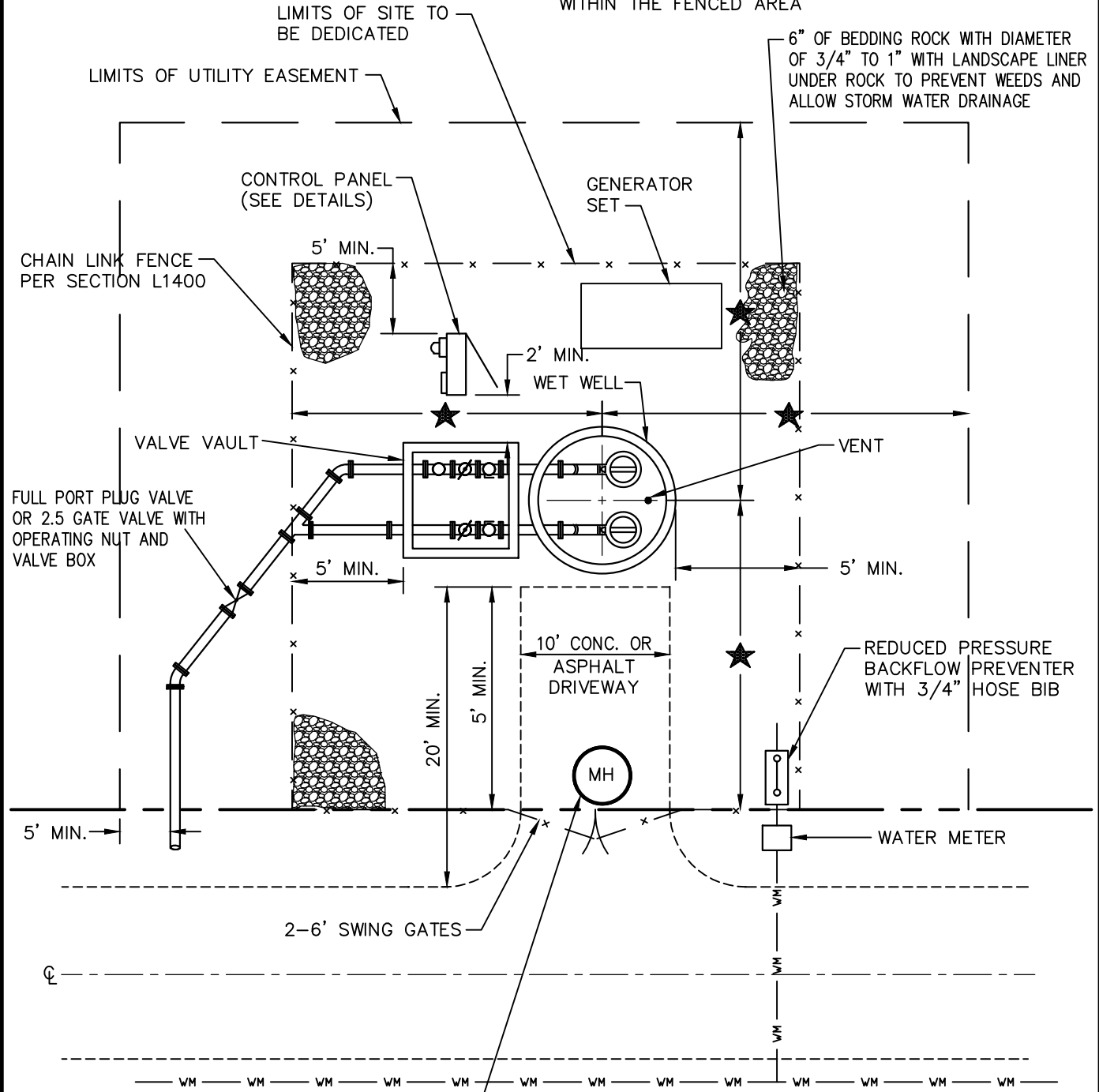

ALL NEW LIFT STATIONS TO HAVE A MANHOLE WITHIN LIMITS OF FENCED-IN AREA TO ALLOW ISOLATION OF WELL DURING BY-PASS OPERATIONS.  
 MODEL; #230-AA-ORS 30" OPENING RING AND COVER

★ THIS DIMENSION SHALL BE EQUAL TO THE DEPTH OF THE WET WELL, AND MUST MEET ALL SETBACK REQUIREMENTS FOUND IN APPENDIX B, ARTICLE VI, SECTION 2(0)

**TYPICAL LIFT STATION SITE PLAN**

REV:	REV:	<b>CITY OF MELBOURNE                  UTILITIES ADMINISTRATION</b>	SCALE:
DATE:	BY:		N.T.S.
7/15/20	JOB NO.:		DWG NO.:
DRAWN BY:	DSGN. BY:		A-501

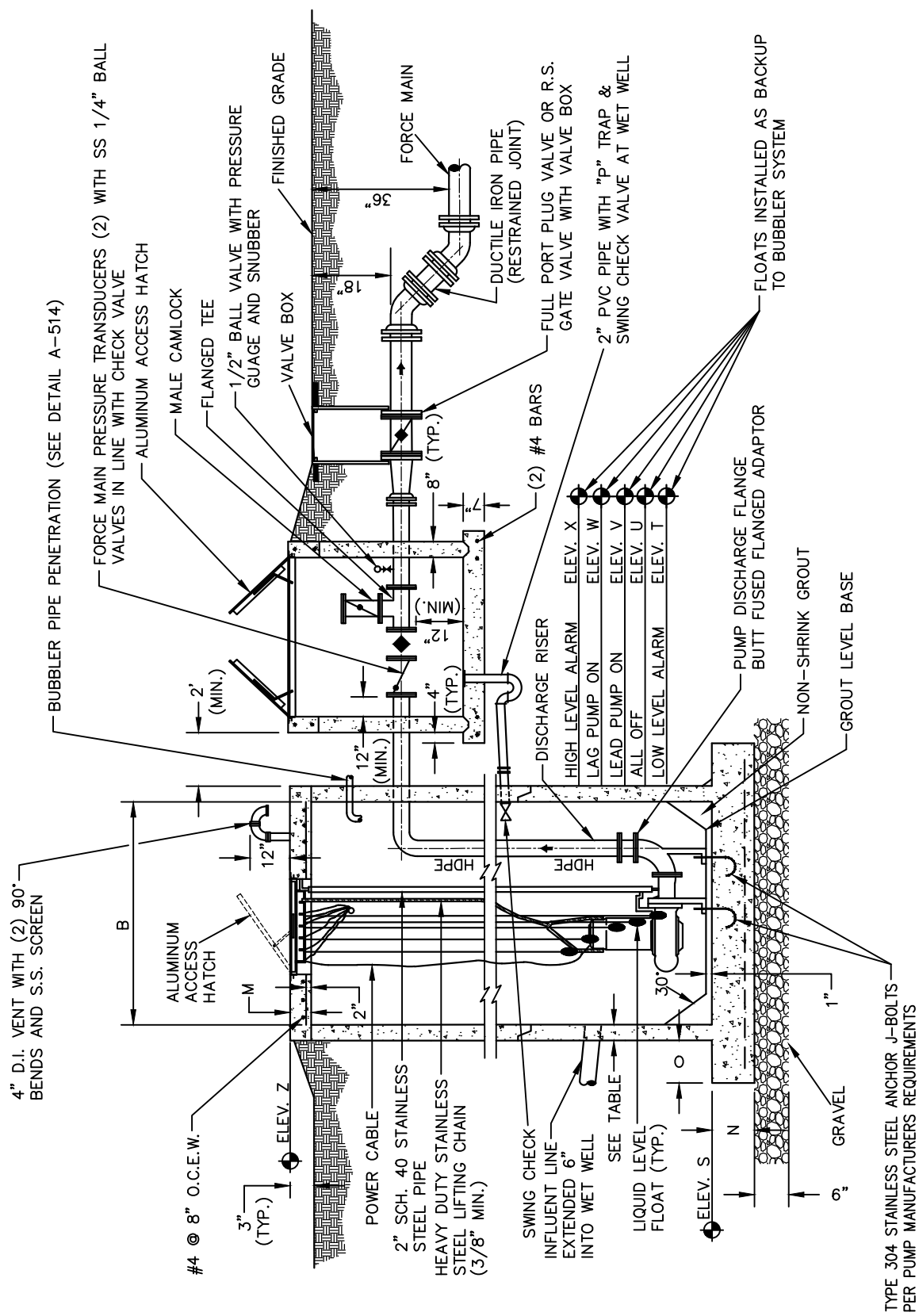

TYPICAL LIFT STATION (PROFILE)

REV:	REV:	CITY OF MELBOURNE UTILITIES ADMINISTRATION	SCALE:
DATE:	BY:		N.T.S.
DRAWN BY:	DSGN. BY:		DWG NO.:
7/15/20			A-502

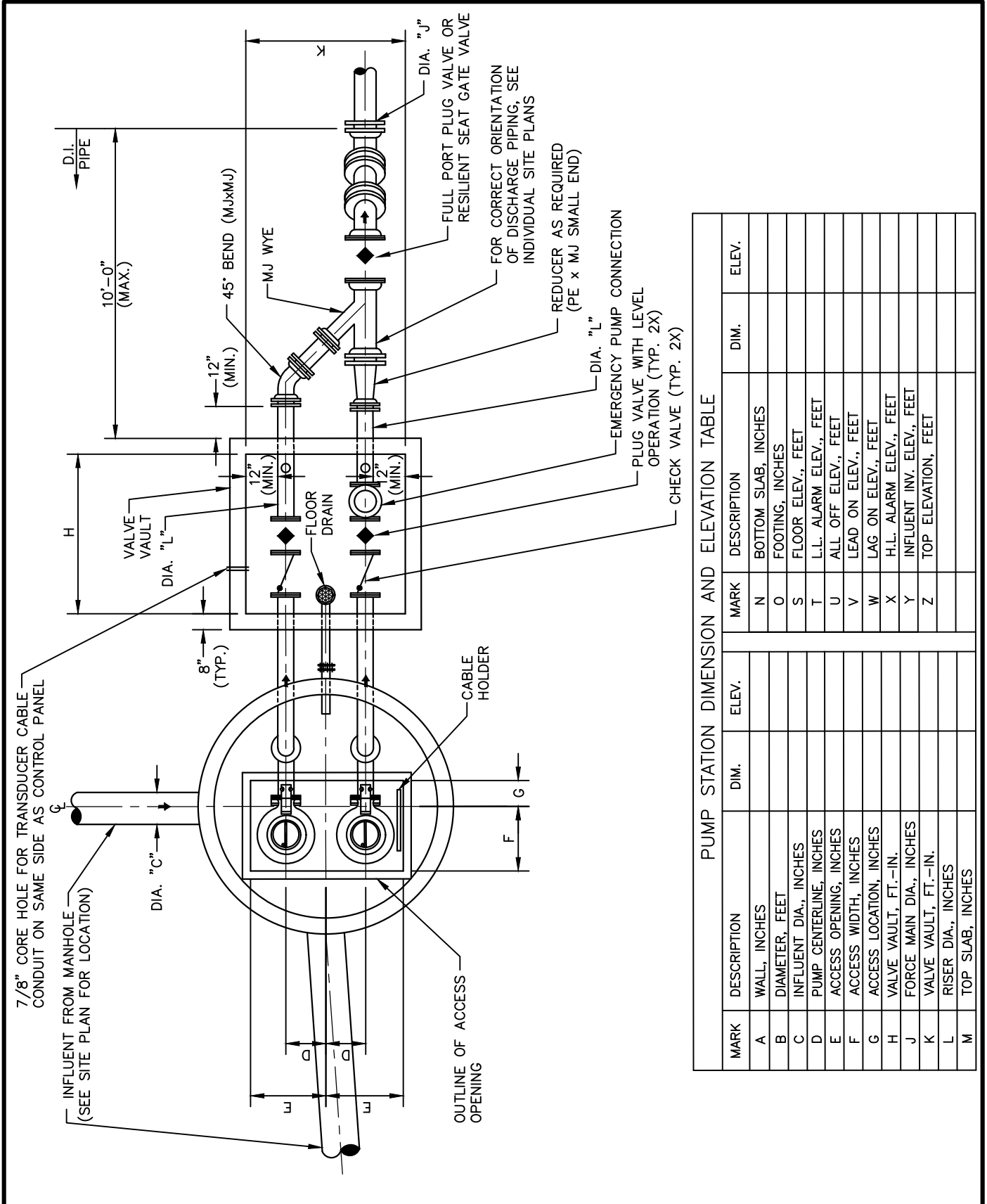

PUMP STATION DIMENSION AND ELEVATION TABLE

MARK	DESCRIPTION	DIM.	ELEV.	MARK	DESCRIPTION	DIM.	ELEV.
A	WALL, INCHES			N	BOTTOM SLAB, INCHES		
B	DIAMETER, FEET			O	FOOTING, INCHES		
C	INFLUENT DIA., INCHES			S	FLOOR ELEV., FEET		
D	PUMP CENTERLINE, INCHES			T	L.L. ALARM ELEV., FEET		
E	ACCESS OPENING, INCHES			U	ALL OFF ELEV., FEET		
F	ACCESS WIDTH, INCHES			V	LEAD ON ELEV., FEET		
G	ACCESS LOCATION, INCHES			W	LAG ON ELEV., FEET		
H	VALVE VAULT, FT.-IN.			X	H.L. ALARM ELEV., FEET		
J	FORCE MAIN DIA., INCHES			Y	INFLUENT INV. ELEV., FEET		
K	VALVE VAULT, FT.-IN.			Z	TOP ELEVATION, FEET		
L	RISER DIA., INCHES						
M	TOP SLAB, INCHES						

## TYPICAL LIFT STATION (PLAN)

REV:	REV. BY:	<b>CITY OF MELBOURNE UTILITIES ADMINISTRATION</b>	SCALE:	N.T.S.
DATE: 7/15/20	JOB NO.:		DWG NO.:	A-503
DRAWN BY:	DSGN. BY:			

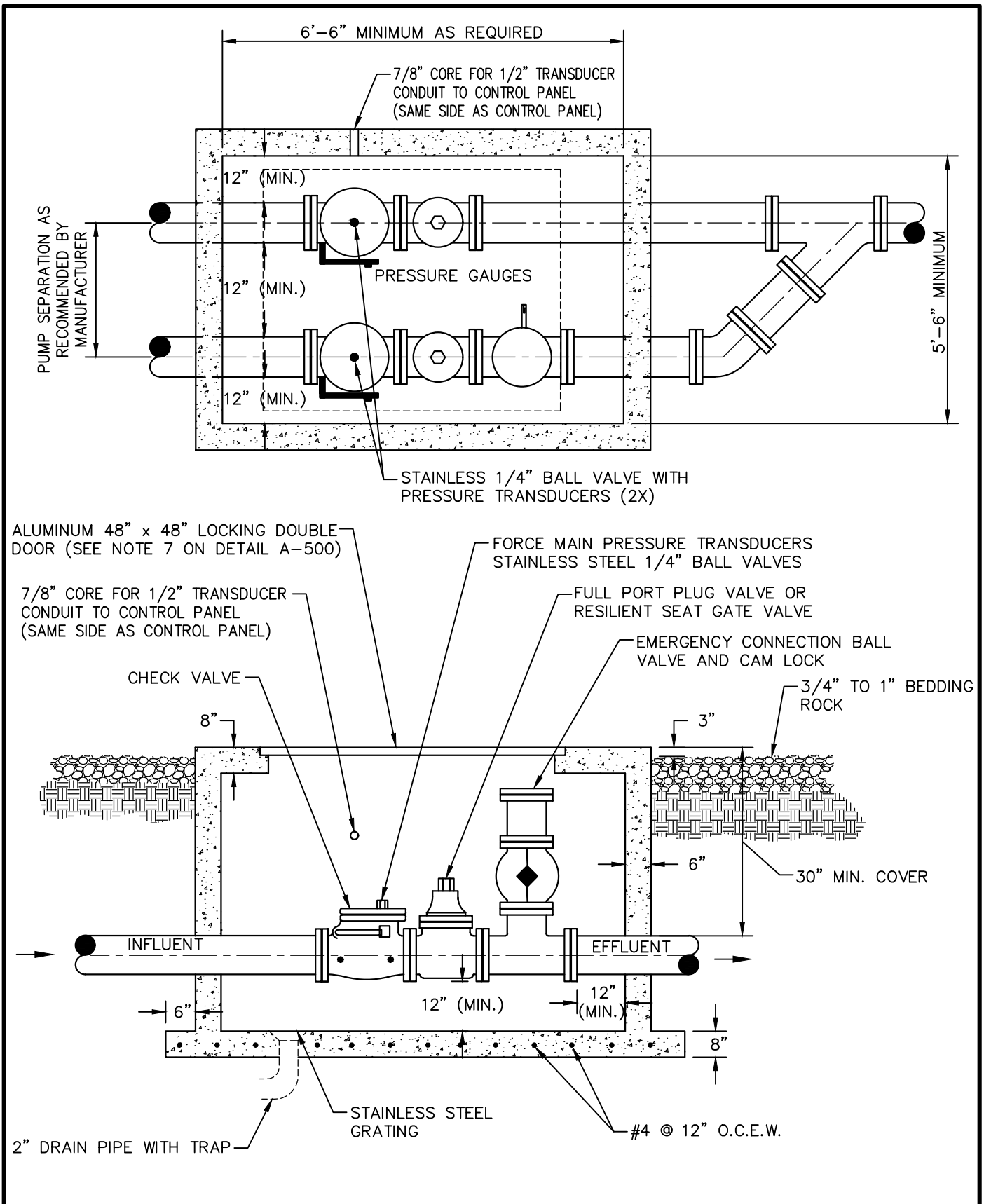

### LIFT STATION VALVE VAULT

REV:	REV:	<b>CITY OF MELBOURNE UTILITIES ADMINISTRATION</b>	SCALE:
DATE: 7/15/20	BY:		N.T.S.
DRAWN BY:	DSGN. BY:		DWG NO.: A-504

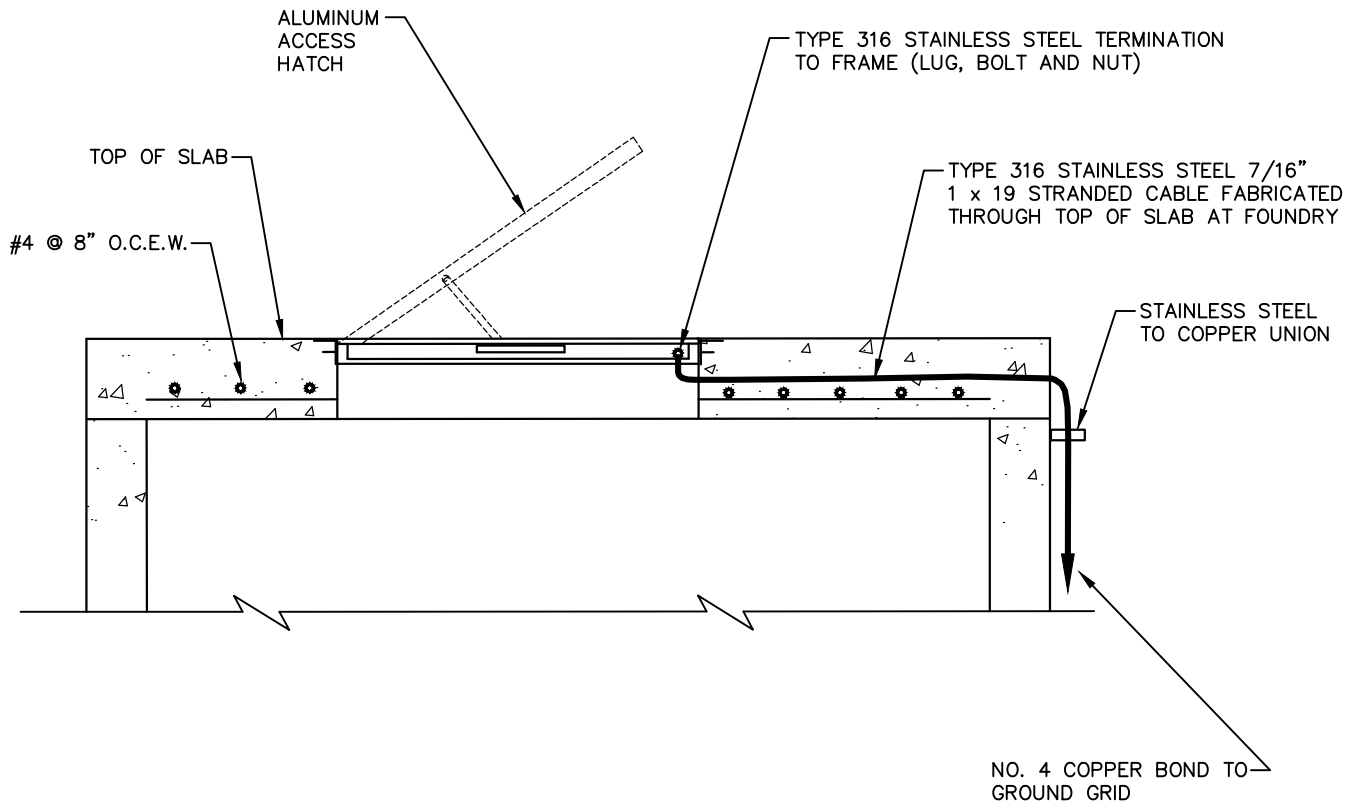

## WET WELL/VALVE VAULT ACCESS HATCH GROUNDING DETAIL

REV:	REV:	<b>CITY OF MELBOURNE UTILITIES ADMINISTRATION</b>	SCALE:	N.T.S.	
DATE: 7/15/20	BY:			DWG	A-505
DRAWN BY:	DSGN. BY:			NO.:	

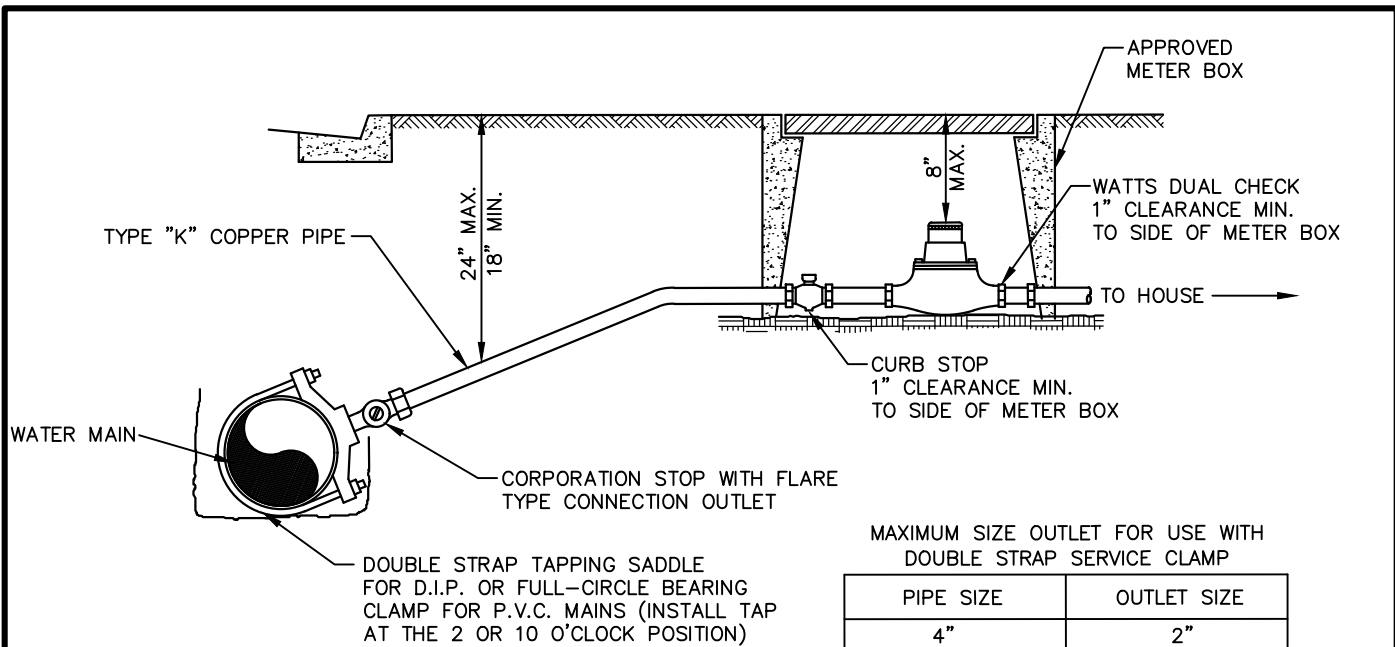

METER TO BE FURNISHED AND INSTALLED BY THE CITY. ALL OTHER COMPONENTS TO BE FURNISHED AND INSTALLED BY CONTRACTOR.

MAXIMUM SIZE OUTLET FOR USE WITH DOUBLE STRAP SERVICE CLAMP

PIPE SIZE	OUTLET SIZE
4"	2"
6"	2"
8"	2"
10"	2"
12" & GREATER	2"

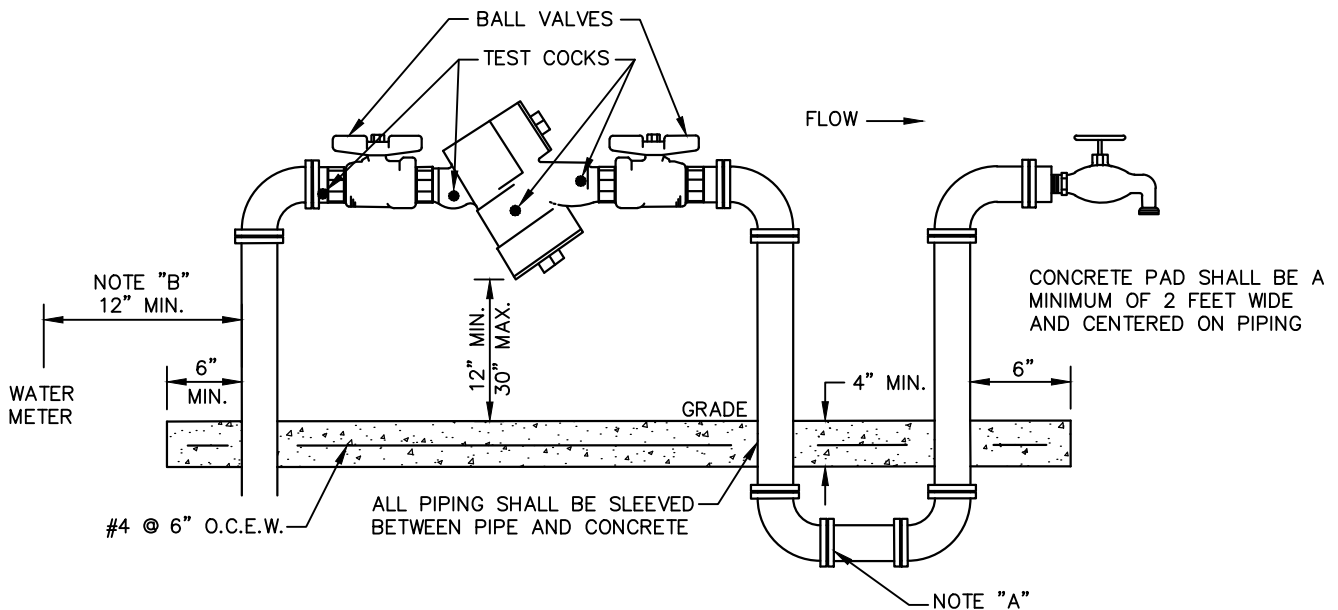

**NOTE A:** ALL PIPING AND FITTINGS SHALL BE SWEATED COPPER OR THREADED BRASS, FROM WATER METER TO THE POINT WHERE THE 90° BEND MEETS THE CUSTOMERS SERVICE LINE UNDERGROUND.

**NOTE B:** BACKFLOW PREVENTER TO BE LOCATED NO LESS THAN 12" DOWNSTREAM FROM WATER METER, AND NO MORE THAN 24".

TYPE OF BACKFLOW PREVENTER TO BE BASED ON DEGREE OF HAZARD. THIS IS TO BE DETERMINED BY THE CITY OF MELBOURNE WATER & SEWER ADMINISTRATOR. DEVICES TO BE INSTALLED IN STRICT ACCORDANCE WITH MANUFACTURES INSTRUCTIONS. BACKFLOW PREVENTER AND ASSOCIATED PIPING TO BE MAINTAINED BY CUSTOMER.

### LIFT STATION POTABLE WATER SERVICE

REV:	REV:	CITY OF MELBOURNE UTILITIES ADMINISTRATION	SCALE:
DATE:	BY		N.T.S.
7/15/20	JOB NO.:		DWG NO.:
DRAWN BY:	DSGN. BY		A-506

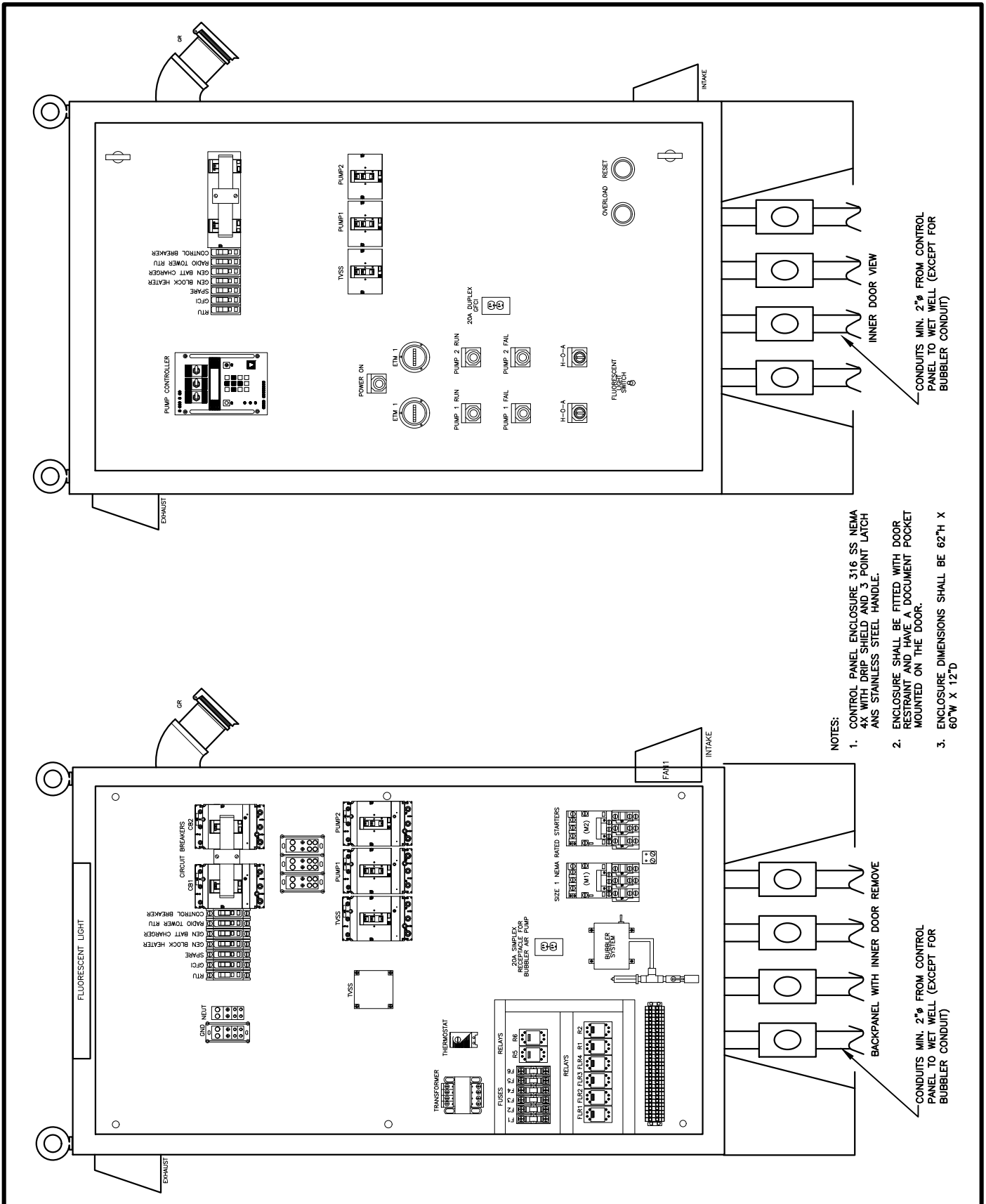

## LIFT STATION CONTROL PANEL – CABINET STYLE DUPLEX

REV:	REV:	CITY OF MELBOURNE UTILITIES ADMINISTRATION	SCALE:
DATE: 7/15/20	BY:		N.T.S.
DRAWN BY:	DSGN. BY:		DWG NO.: A-507



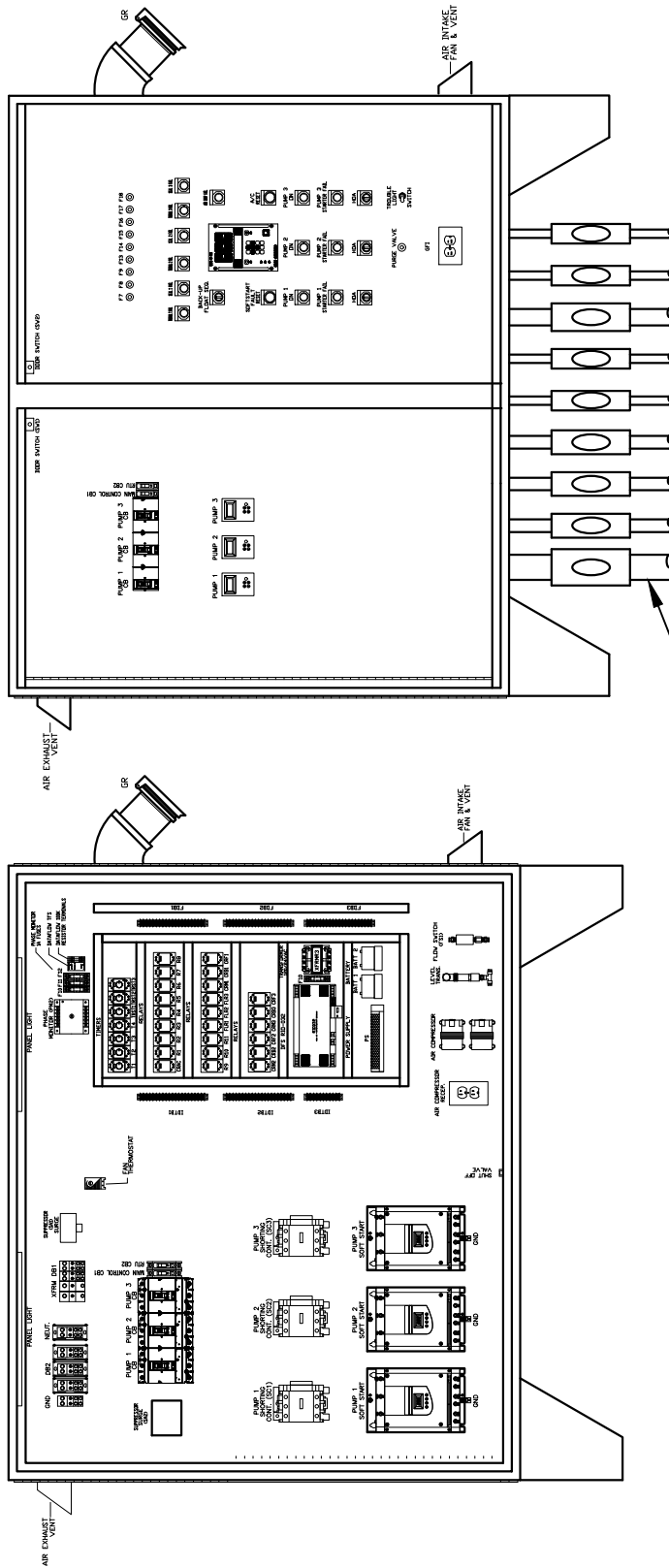

PUMP, POWER, AND CONTROL CONDUITS

CONDUITS MIN. 2"Ø FROM CONTROL PANEL TO WET WELL (EXCEPT FOR BUBBLER CONDUIT)

NOTES:  
 ENCLOSURE SHALL BE NEMA 3R 316 12 GA. STAINLESS STEEL 60" H X 72" W X 16" D  
 WITH LEGS, POWDER COATED WHITE  
 LEXANGLASS COVER PROTECTION & STUDS FOR POWER SIDE AND BACK DOOR.

### LIFT STATION CONTROL PANEL – CABINET STYLE TRIPLEX

REV:	REV:	CITY OF MELBOURNE UTILITIES ADMINISTRATION	SCALE:
DATE: 7/15/20	BY:		N.T.S.
DRAWN BY:	DSGN. BY:		DWG NO.: A-508

SERVICE ENTRANCE RATED, MANUAL TRANSFER SWITCH

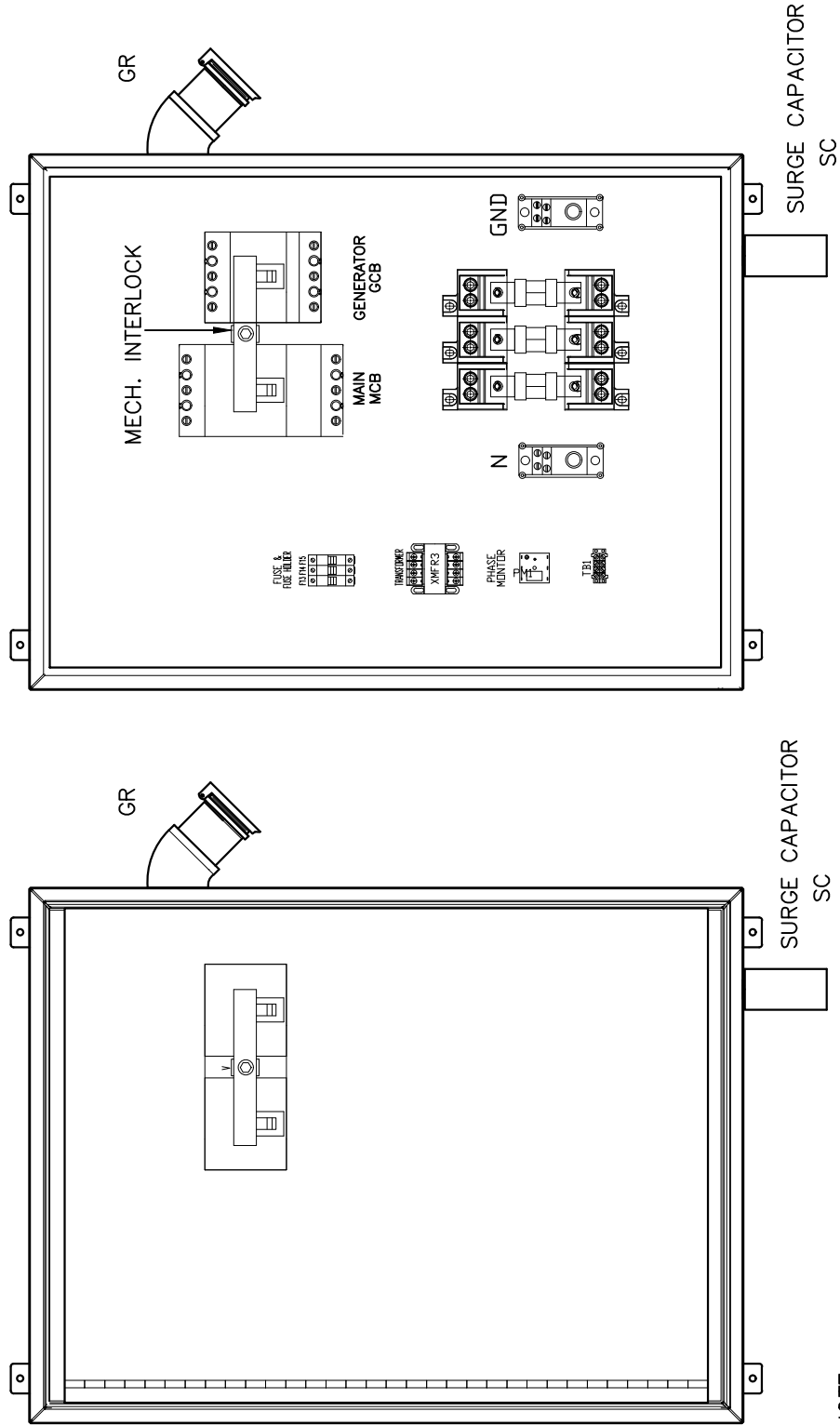

NOTE:  
ENCLOSURE SIZE: 42H X 36W X 12D 3R S/S

SERVICE RATED MANUAL TRANSFER SWITCH LAYOUT

REV:	REV:	CITY OF MELBOURNE UTILITIES ADMINISTRATION	SCALE:
DATE: 7/15/20	BY:		N.T.S.
DRAWN BY:	DSGN. BY:		DWG NO. A-509

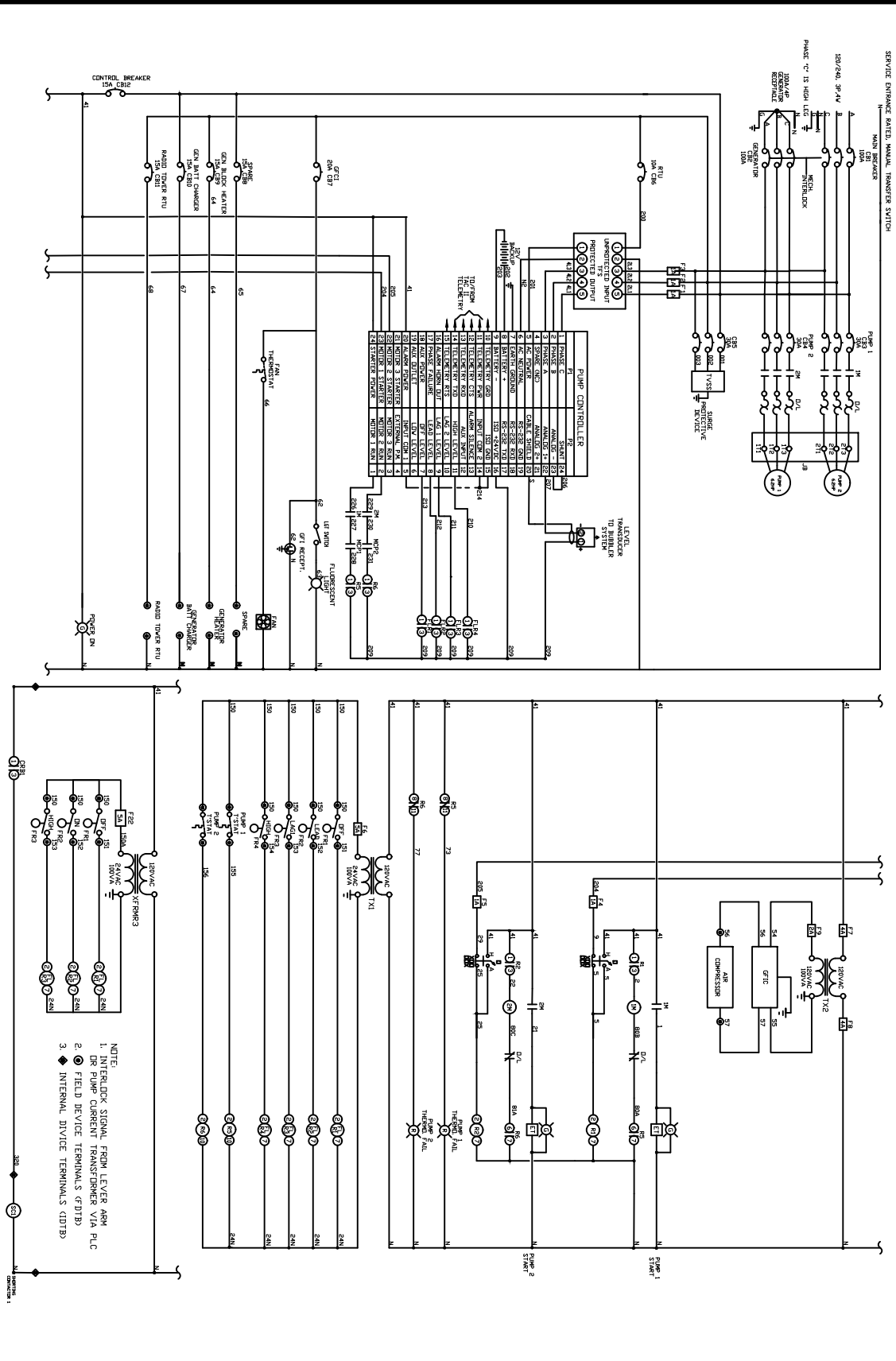

## WIRING DIAGRAM – TYPICAL DUPLEX PUMP CONTROLS, 240 V

REV:	REV:	<h3 style="margin: 0;">CITY OF MELBOURNE UTILITIES ADMINISTRATION</h3>	SCALE:
DATE: 7/15/20	BY:		N.T.S.
DRAWN BY:	DSGN. BY:		DWG NO.: A-510

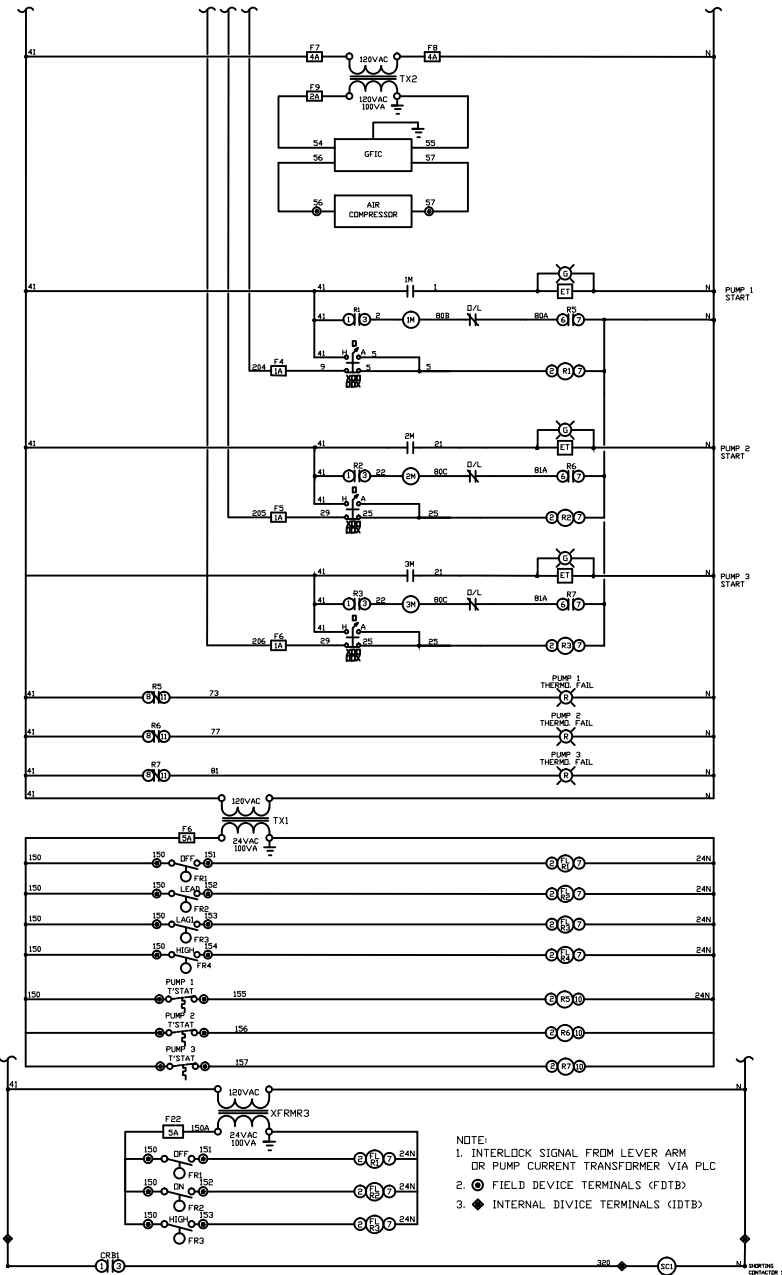
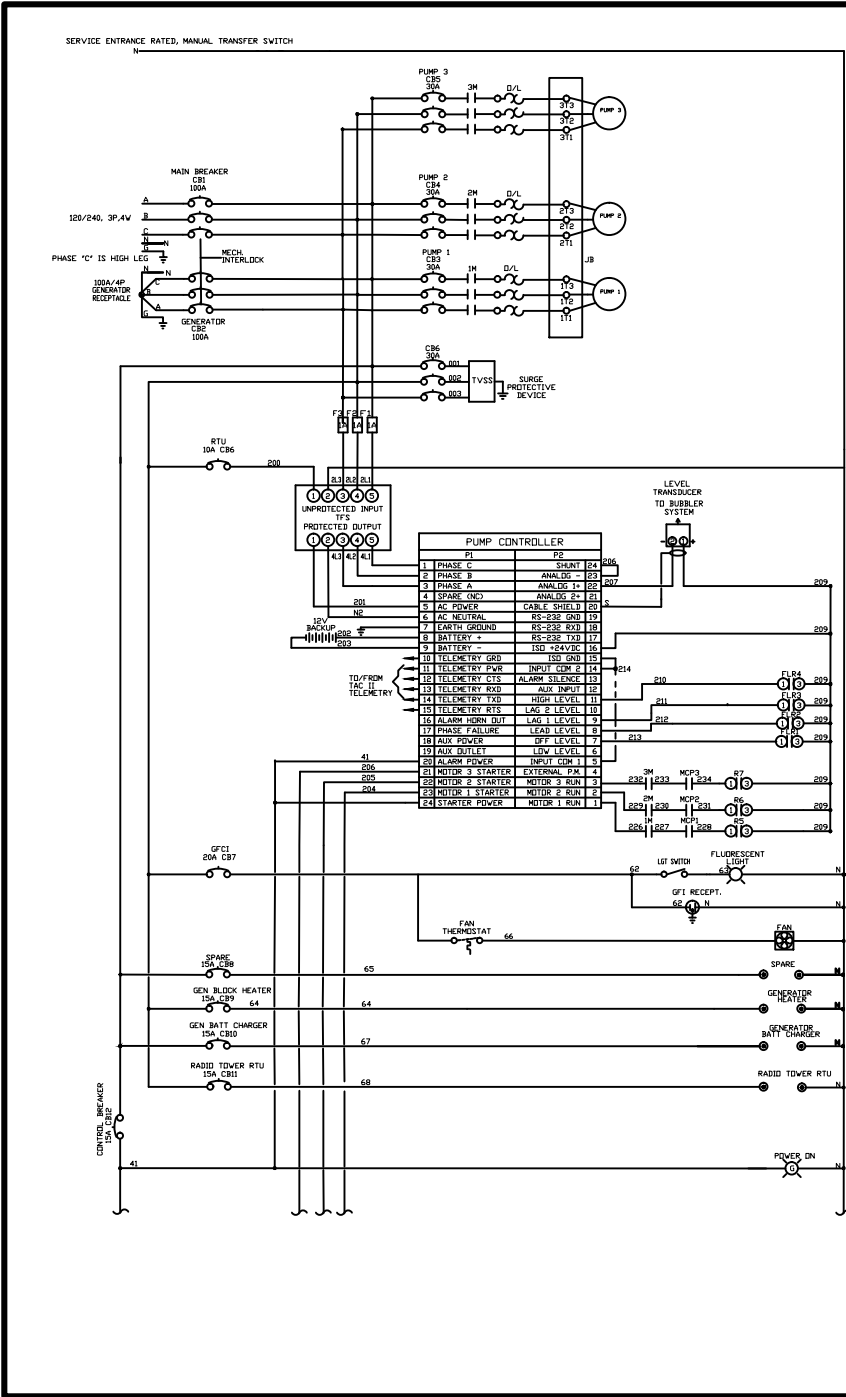

WIRING DIAGRAM - TYPICAL TRIPLEX PUMP CONTROLS, 240 V

REV:	REV. BY:	CITY OF MELBOURNE UTILITIES ADMINISTRATION	SCALE:	N.T.S.
DATE:	7/15/20		DWG. NO.:	A-511
DRAWN BY:				

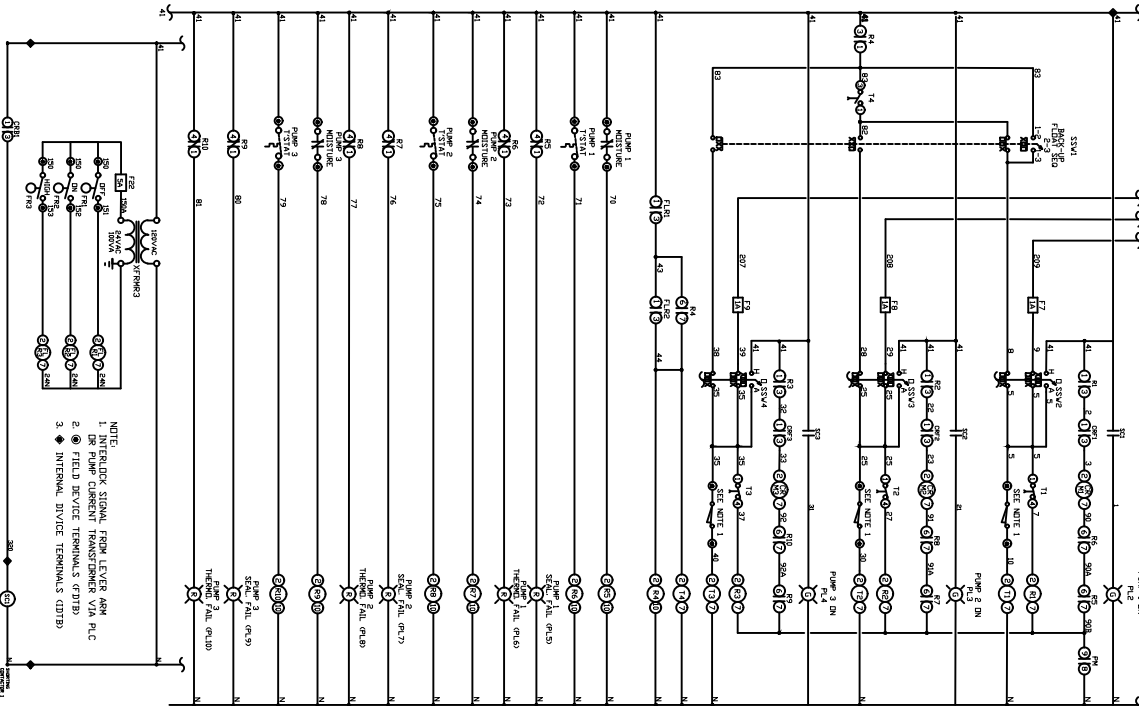
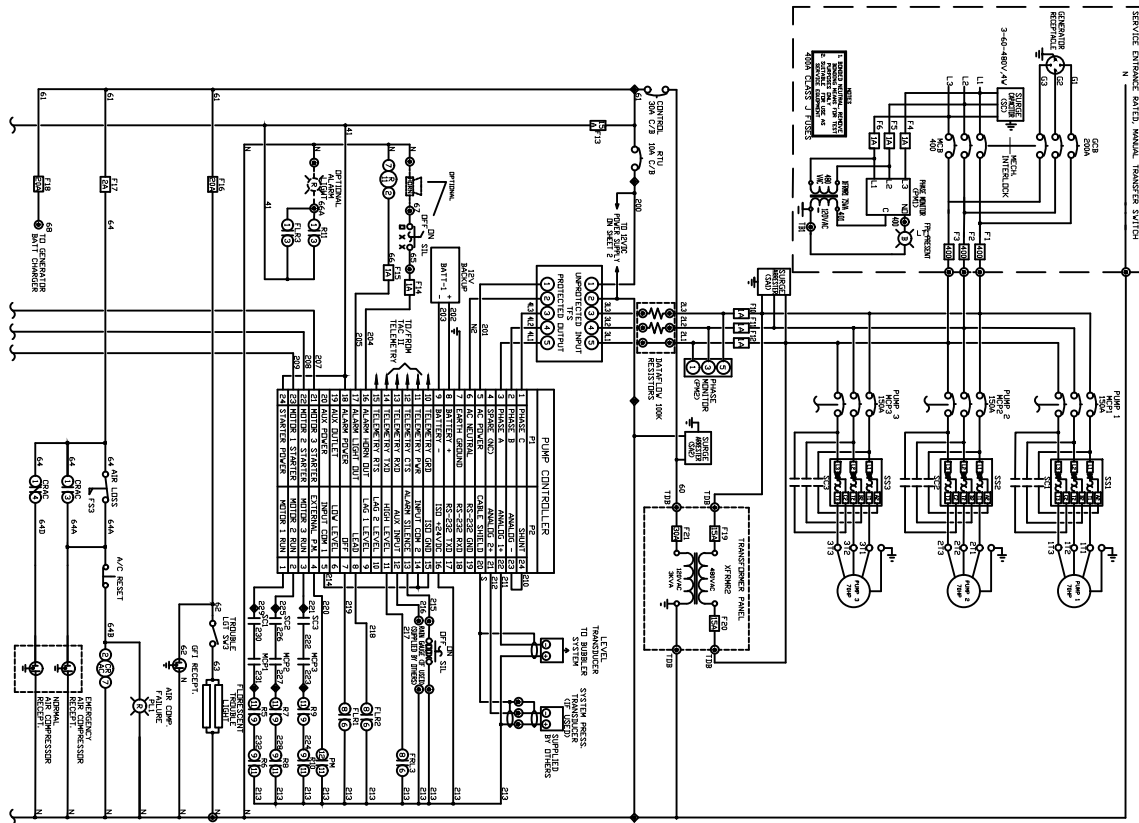

**WIRING DIAGRAM – TYPICAL TRIPLEX PUMP CONTROLS, 480 V**

REV: \_\_\_\_\_  
DATE: 7/15/20  
DRAWN BY: \_\_\_\_\_

REV: \_\_\_\_\_  
BY: \_\_\_\_\_  
JOB NO.: \_\_\_\_\_  
DSGN. BY: \_\_\_\_\_

**CITY OF MELBOURNE  
UTILITIES ADMINISTRATION**

SCALE: N.T.S.  
DWG NO.: A-512

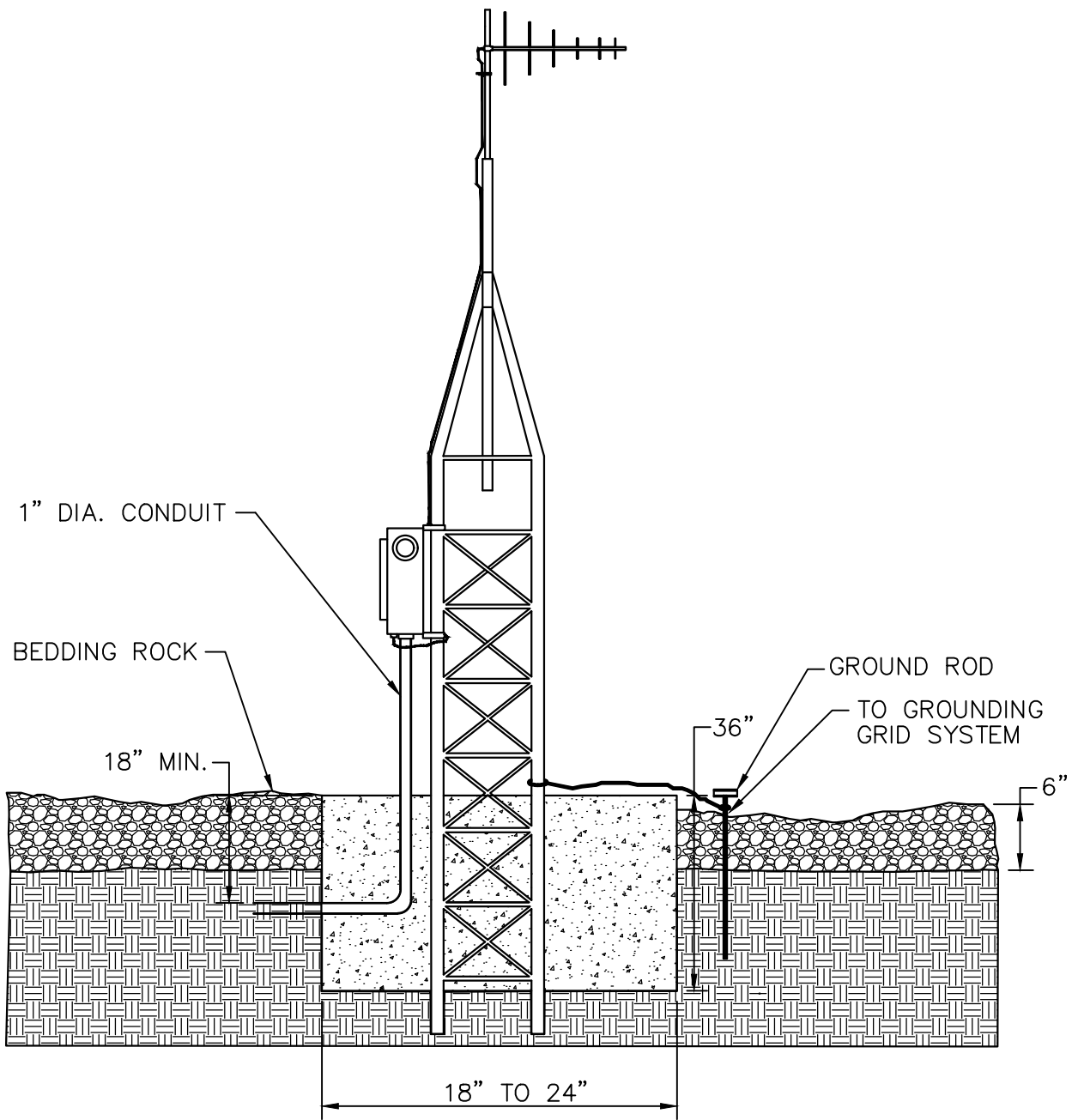

### RADIO TOWER LAYOUT – REMOTE SITE

REV:	REV:	<b>CITY OF MELBOURNE UTILITIES ADMINISTRATION</b>	SCALE:
DATE:	BY:		N.T.S.
7/15/20	JOB NO.:		DWG NO.:
DRAWN BY:	DSGN. BY:		A-513

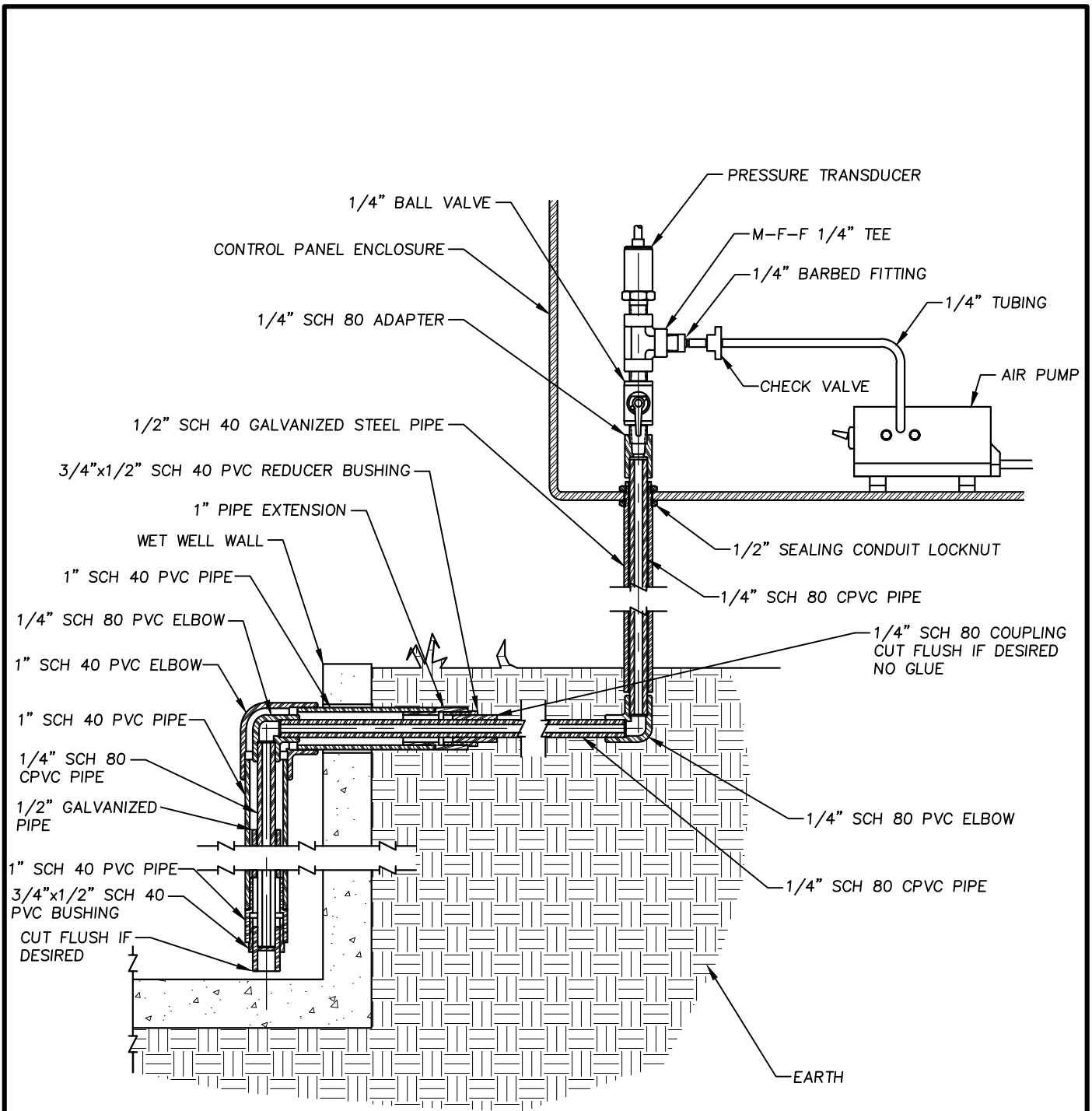

### BUBBLER ASSEMBLY

REV:	REV: BY	<b>CITY OF MELBOURNE          UTILITIES ADMINISTRATION</b>	SCALE: N.T.S.
DATE: 7/15/20	JOB NO.:		DWG NO.: A-514
DRAWN BY:	DSGN. BY		

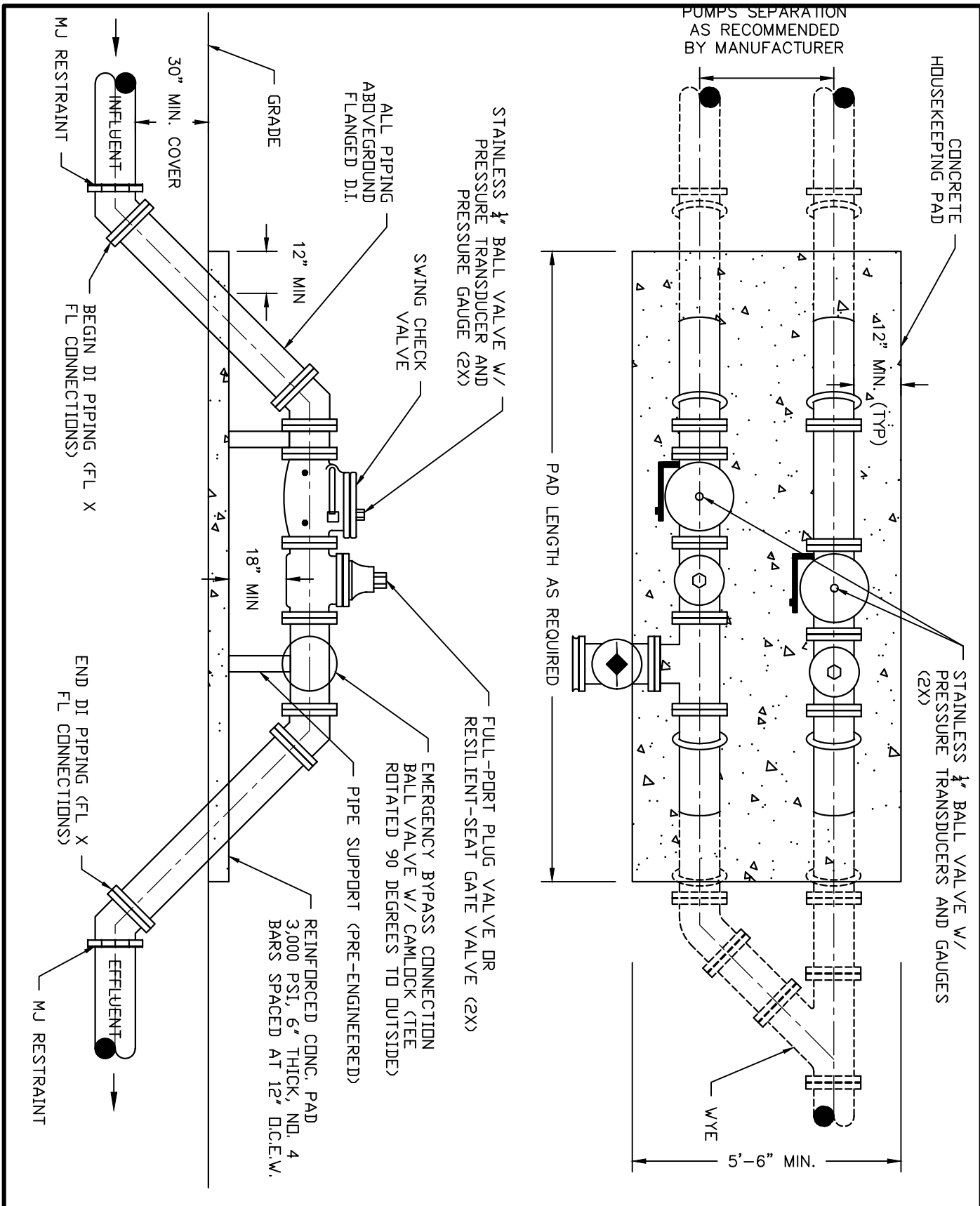

LIFT STATION ABOVE-GROUND VALVE PAD

REV:	REV:
DATE: 7/12/21	BY:
DRAWN BY:	DSGN. BY:

CITY OF MELBOURNE  
 UTILITIES ADMINISTRATION

SCALE:	N.T.S.
DWG NO.:	A-515



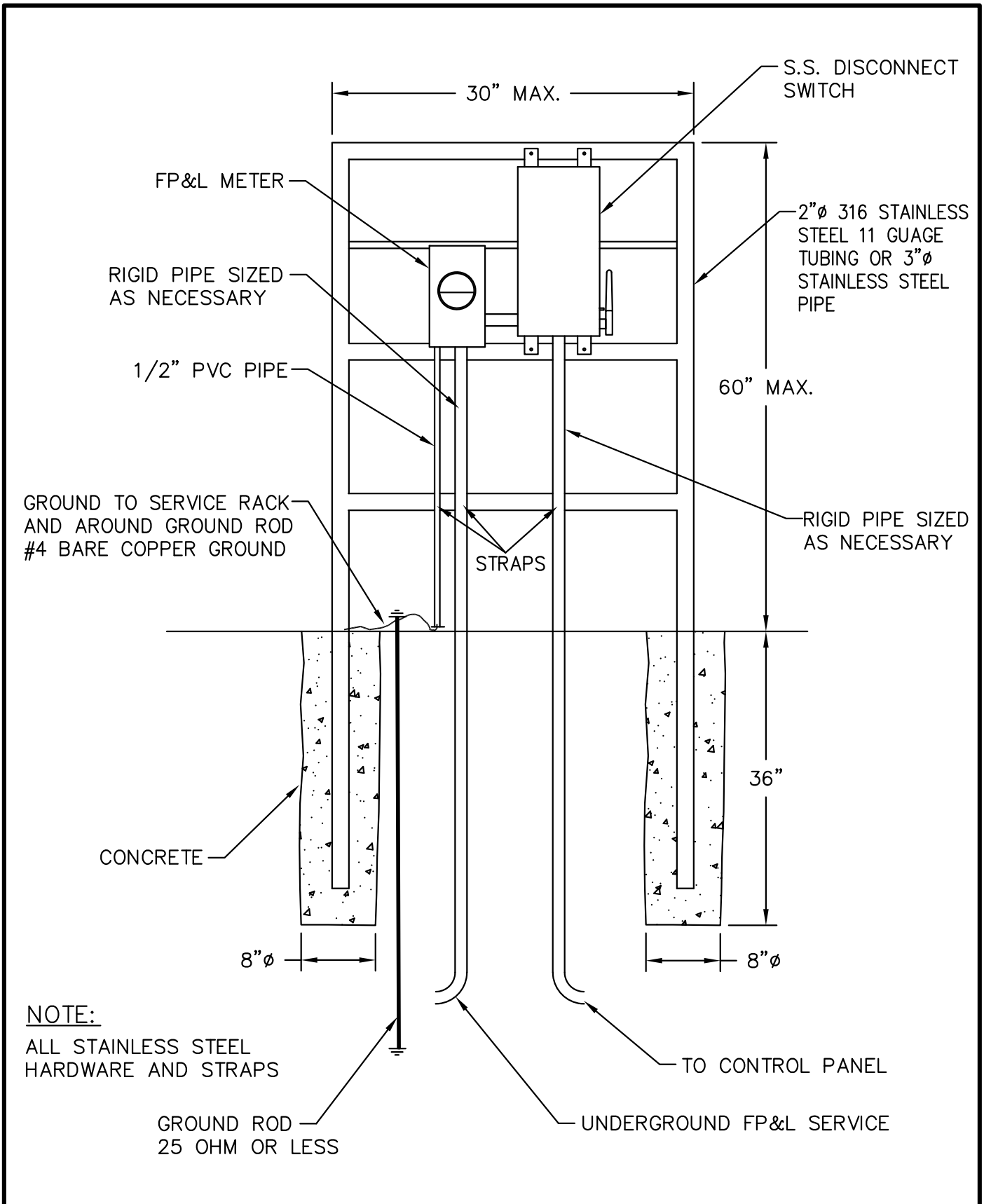

**NOTE:**  
 ALL STAINLESS STEEL  
 HARDWARE AND STRAPS

**LIFT STATION SERVICE DISCONNECT DETAIL**

REV:	REV:	<b>CITY OF MELBOURNE          UTILITIES ADMINISTRATION</b>	SCALE:
DATE: 1/30/2024	BY:		N.T.S.
DRAWN BY: JRP	DSGN. BY: MB		DWG NO.: A-516